

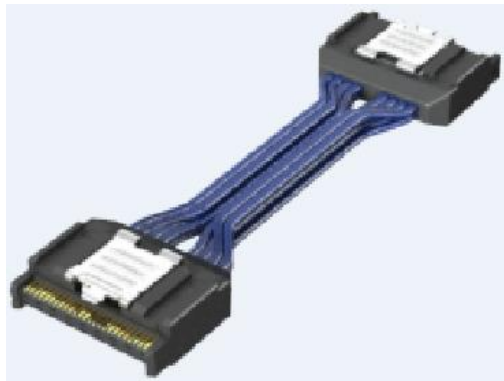

High Speed Characterization Report

ARC6-16-XX.X-LU-LU-3-1



Mated with:

ARF6-16-X-D-A-X-TR

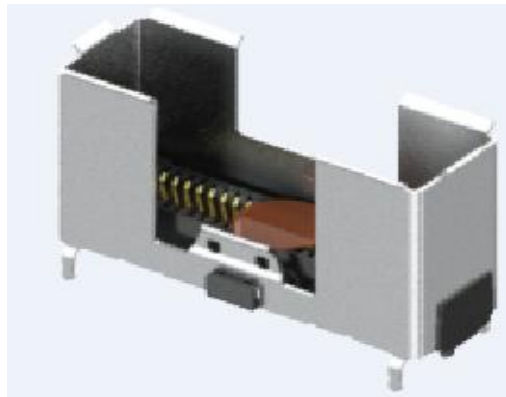

Description:

**0.635 mm AcceleRate® Slim Body Cable Assembly,
34 AWG, 100 Ω Eye Speed® ultra low skew twinax cable**

Series: ARC6

Description: 0.635 mm AcceleRate® Slim Body Cable Assembly, 34 AWG, 100 Ω
Eye Speed® ultra low skew twinax cable

Table of Contents

Cable Assembly Overview	3
Frequency Domain Data Summary	4
Bandwidth Figures – Differential Insertion Loss	4
Time Domain Data Summary	5
Characterization Details	6
Differential and Single-Ended Data	6
Cable assembly Signal to Ground Ratio	7
Frequency Domain Data	9
Time Domain Data	9
Appendix A – Frequency Domain Responses	10
Differential Application – Insertion Loss	10
Differential Application – Return Loss	11
Differential Application – NEXT Configurations	13
Differential Application – FEXT Configurations	19
Differential Application – Differential to Common Mode Conversion	22
Appendix B – Time Domain Responses	24
Differential Application – Input Pulse	24
Differential Application – Cable assembly Impedance	24
Differential Application – Cable assembly Impedance	25
Differential Application – Propagation Delay	29
Appendix C – Product and Test System Descriptions	33
Product Description	33
Test System Description	33
PCB-109926-SIG Test Fixtures	33
PCB Fixtures	34
Appendix D – Test and Measurement Setup	36
N5227B Measurement Setup	36
Test Instruments	36
Test Cables & Adapters	36
DCA-X86100D Measurement Setup	37
Test Instruments	37
Test Cables & Adapters	37
Appendix E - Frequency and Time Domain Measurements	38
Frequency (S-Parameter) Domain Procedures	38
Time Domain Procedures	38
Propagation Delay (TDT)	38
Impedance (TDR)	39
Appendix F – Glossary of Terms	40

Series: ARC6

Description: 0.635 mm AcceleRate® Slim Body Cable Assembly, 34 AWG, 100 Ω Eye Speed® ultra low skew twinax cable

Cable Assembly Overview

The 0.635 mm (.025") ARC6 Slim Body Cable Assembly is constructed using 34 AWG, 100 Ω Eye Speed® ultra low skew twinax cable. The cable is terminated at both ends with connector on a printed circuit board. The cable assembly is wired to facilitate a Pin 1 to Pin N-1 mapping between the cable terminations. The ARC6 series cable assemblies are available in 8 and 16 pairs per row. The data in this report is only applicable to 250 mm, 500 mm and 1000 mm length cable assembly.

Each ARC6 cable assembly was tested by mating it to ARF6 socket at both ends. One sample of each assembly was tested. The actual part numbers that were tested are shown in Table 1, which also identifies End 1 and End 2 of each assembly. A relative sample picture is shown in Figure 1.

Length	Part Number	End 1	End 2
250 mm	ARC6-16-10.0-LU-LU-3-1	LU	LU
500 mm	ARC6-16-20.0-LU-LU-3-1	LU	LU
1000 mm	ARC6-16-40.0-LU-LU-3-1	LU	LU

Table 1: Sample Description



Figure 1: Test Sample

Series: ARC6

Description: 0.635 mm AcceleRate® Slim Body Cable Assembly, 34 AWG, 100 Ω Eye Speed® ultra low skew twinax cable

Frequency Domain Data Summary

Bandwidth Figures – Differential Insertion Loss

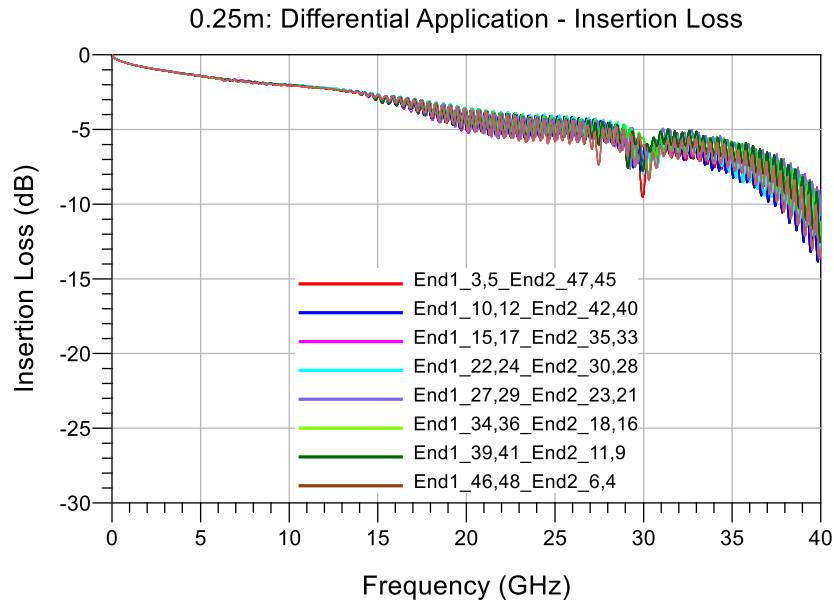

Figure 2

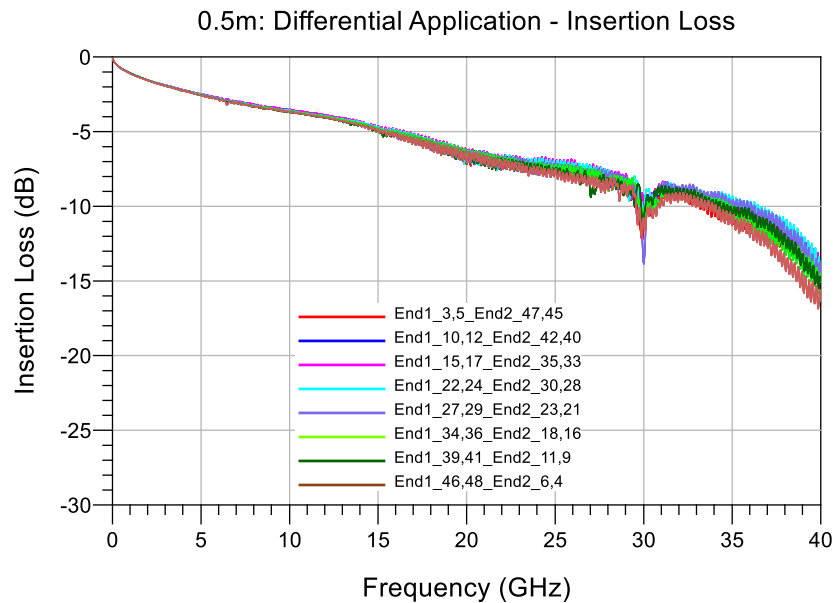

Figure 3

Series: ARC6

Description: 0.635 mm AcceleRate® Slim Body Cable Assembly, 34 AWG, 100 Ω Eye Speed® ultra low skew twinax cable

1m: Differential Application - Insertion Loss

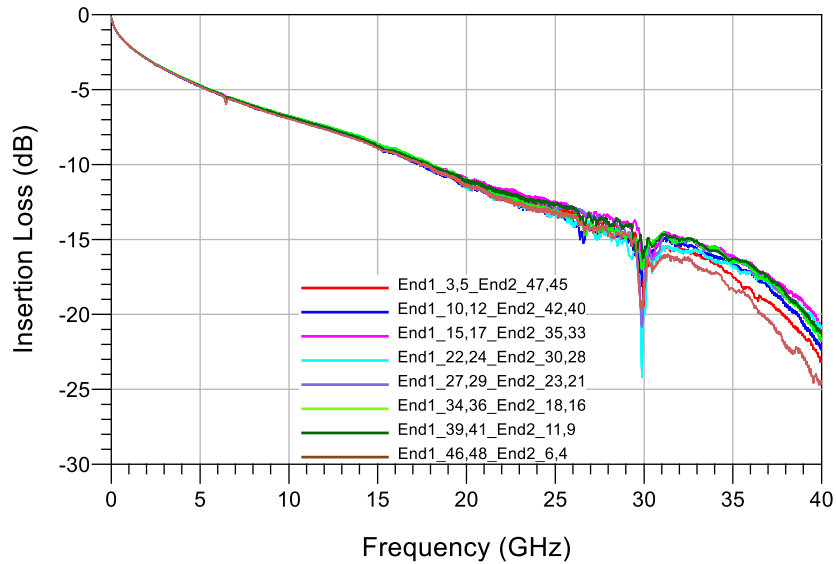

Figure 4

Time Domain Data Summary

0.25 m: Differential Application - Impedance

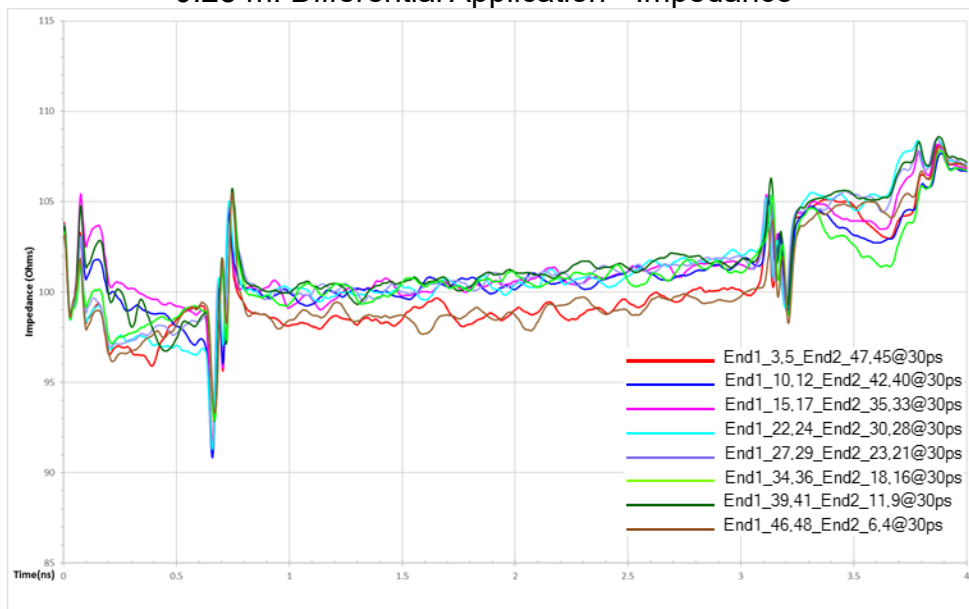

Figure 5

Because the same type cable is used in the cable assemblies with different lengths, only the impedance profile of 0.25 m cable assembly is reported.

Series: ARC6

Description: 0.635 mm AcceleRate® Slim Body Cable Assembly, 34 AWG, 100 Ω
Eye Speed® ultra low skew twinax cable

Table 2 - Propagation Delay (Cable Assembly)				
Driver	Receiver	0.25 m	0.5 m	1 m
End 1_3,5	End 2_47,45	1.292 ns	2.499 ns	4.914 ns
End 1_10,12	End 2_42,40	1.297 ns	2.506 ns	4.918 ns
End 1_15,17	End 2_35,33	1.291 ns	2.498 ns	4.914 ns
End 1_22,24	End 2_30,28	1.291 ns	2.495 ns	4.898 ns
End 1_27,29	End 2_23,21	1.286 ns	2.492 ns	4.901 ns
End 1_34,36	End 2_18,16	1.293 ns	2.503 ns	4.913 ns
End 1_39,41	End 2_11,9	1.290 ns	2.502 ns	4.917 ns
End 1_46,48	End 2_6,4	1.292 ns	2.504 ns	4.914 ns

Characterization Details

This report presents data that characterizes the signal integrity response of a cable assembly in a controlled printed circuit board (PCB) environment. All efforts are made to reveal typical best-case responses inherent to the system under test (SUT).

In this report, the SUT includes the mating connectors, cable assembly, and footprint effects on a typical multi-layer PCB. PCB effects (trace loss) are de-embedded from test data. Board related effects, such as pad-to-ground capacitance, are included in the data presented in this report.

Additionally, intermediate test signal connections can mask the cable assembly's true performance. Such connection effects are minimized by using high performance test cables and adapters. Where appropriate, calibration and de-embedding routines are also used to reduce residual effects.

Differential and Single-Ended Data

Most Samtec cable assemblies can be used successfully in both differential and single-ended applications. However, electrical performance will differ depending on the signal drive type. In this report, data is presented for "GSSG" differential drive configuration only.

Series: ARC6

Description: 0.635 mm AcceleRate® Slim Body Cable Assembly, 34 AWG, 100 Ω Eye Speed® ultra low skew twinax cable

Cable assembly Signal to Ground Ratio

Samtec cable assemblies are most often designed for generic applications and can be implemented using various signal and ground pin assignments. In high speed systems, provisions must be made in the interconnect for signal return currents. Such paths are often referred to as “ground”. In some cable assemblies, a ground plane or blade, or an outer shield, is used as the signal return, while in others, cable assembly pins are used as signal returns. Various combinations of signal pins, ground blades, and shields can also be utilized. Electrical performance can vary significantly depending upon the number and location of ground pins.

In general, the more pins dedicated to ground, the better electrical performance will be. But dedicating pins to ground reduces signal density of a cable assembly. Therefore, care must be taken when choosing signal/ground ratios in cost or density-sensitive applications.

For this cable assembly, the following configurations are evaluated:

1	3	5	7	9	11	13	15	17	19	21	23	25	27	29	31	33	35	37	39	41	43	45	47	49
G	PAIR	G	PAIR	G	PAIR	G	PAIR	G	PAIR	G	PAIR	G	PAIR	G	PAIR	G	PAIR	G	PAIR	G	PAIR	G	PAIR	G
2	4	6	8	10	12	14	16	18	20	22	24	26	28	30	32	34	36	38	40	42	44	46	48	50

Respective signal line numbers as viewed from End 1

Differential Impedance (denoted by green circles):

- GSSG (Ground-positive signal-negative signal-Ground)

Differential Crosstalk (denoted by red circles):

- In row: from the terminals to the other terminals on the same row.
- Across row: from one row of terminals to the other row of terminals.

See [Appendix C](#) – Product and Test System Descriptions for details

Other configurations can be evaluated upon request. Please contact sig@samtec.com for more information.

In a real system environment, active signals might be located at the outer edges of the signal contacts of concern, as opposed to the ground signals utilized in laboratory testing. For example, in a single-ended system, a pin-out of “SSSS”, or four adjacent single ended signals might be encountered as opposed to the “GSG” and “GSSG” configurations tested in the laboratory. Electrical characteristics in such applications could vary slightly

Series: ARC6

Description: 0.635 mm AcceleRate® Slim Body Cable Assembly, 34 AWG, 100 Ω
Eye Speed® ultra low skew twinax cable

from laboratory results. But in most applications, performance can safely be considered equivalent.

Signal Edge Speed (Rise Time)

In pulse signaling applications, the perceived performance of the interconnect can vary significantly depending on the edge rate or rise time of the exciting signal. For this report, the fastest rise time used was 20 ps. Generally, this should demonstrate worst-case performance.

In many systems, the signal edge rate will be significantly slower at the cable assembly than at the driver launch point. To estimate interconnect performance at other edge rates, data is provided for several rise times between 20 ps and 50 ps.

For this report, measured rise times were at 20%-80% signal levels.

Series: ARC6

Description: 0.635 mm AcceleRate® Slim Body Cable Assembly, 34 AWG, 100 Ω
Eye Speed® ultra low skew twinax cable

Frequency Domain Data

Frequency Domain parameters are helpful in evaluating the cable assembly system's signal loss and crosstalk characteristics across a range of sinusoidal frequencies. In this report, parameters presented in the Frequency Domain are Insertion Loss, Return Loss, Near-End and Far-End Crosstalk, and Mode Conversion. Other parameters or formats, such as VSWR or S-Parameters, may be available upon request. Please contact our Signal Integrity Group at sig@samtec.com for more information.

Frequency performance characteristics for the SUT are generated directly from network analyzer measurements.

Time Domain Data

Time Domain parameters indicate Impedance mismatch versus length and signal propagation time in a pulsed signal environment.

Impedance mismatch versus length is measured by DCA-X86100D Digital Serial Analyzer. Board related effects, such as pad-to-ground capacitance and trace loss, are included in the data presented in this report. The impedance data is provided in [Appendix B](#) of this report.

The measured S-Parameters from the network analyzer are post-processed using Keysight ADS to obtain the time domain response for signal propagation time. The Time Domain procedure is provided in [Appendix D](#) of this report. Parameters or formats not included in this report may be available upon request. Please contact our Signal Integrity Group at sig@samtec.com for more information.

In this report, propagation delay is defined as the signal propagation time through the cable assembly, mating connectors, and connector footprint. It also includes 50 mils of PCB trace on each connector side. Delay is measured at 50 picoseconds signal rise-time. Delay is calculated as the difference in time measured between the 50% amplitude levels of the input and output pulses.

Data for other configurations may be available. Please contact our Signal Integrity Group at sig@samtec.com for further information.

Additional information concerning test conditions and procedures is located in the appendices of this report. Further information may be obtained by contacting our Signal Integrity Group at sig@samtec.com.

Series: ARC6

Description: 0.635 mm AcceleRate® Slim Body Cable Assembly, 34 AWG, 100 Ω
Eye Speed® ultra low skew twinax cable

Appendix A – Frequency Domain Responses

Differential Application – Insertion Loss

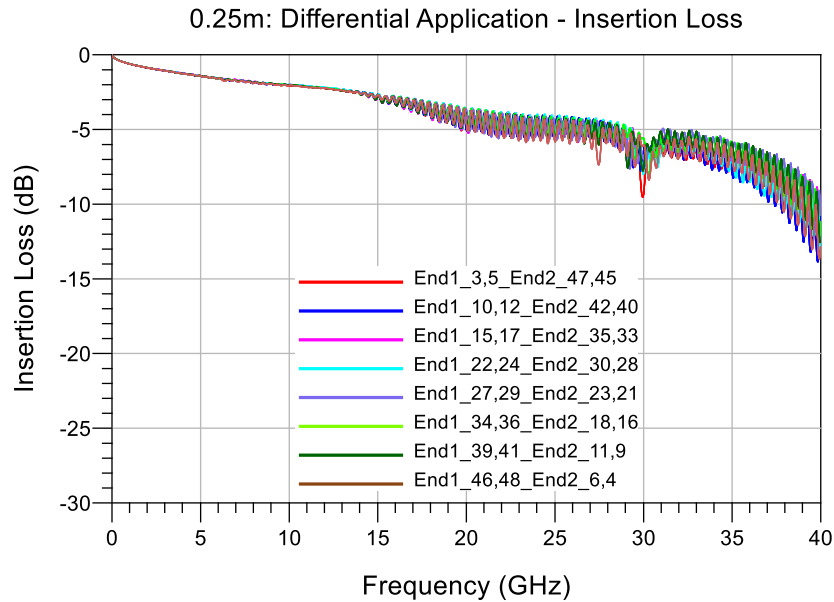

Figure 6

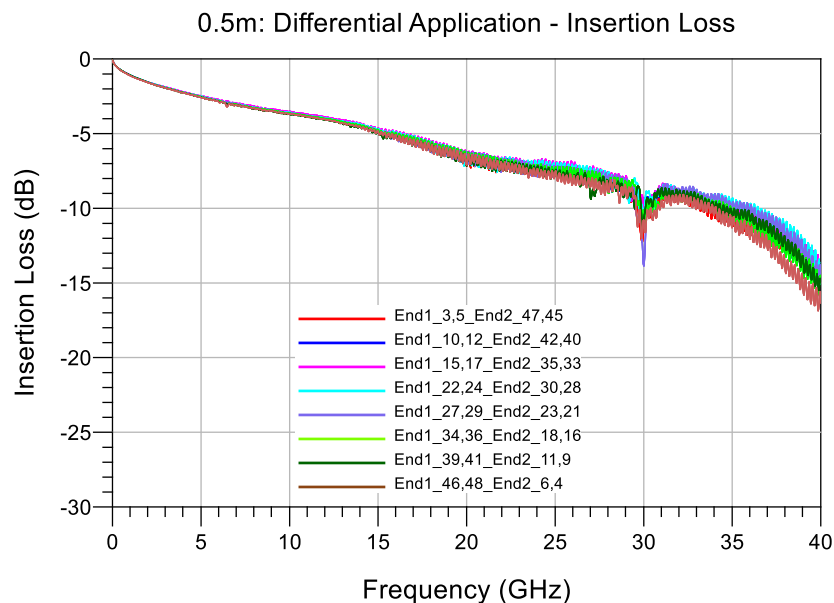
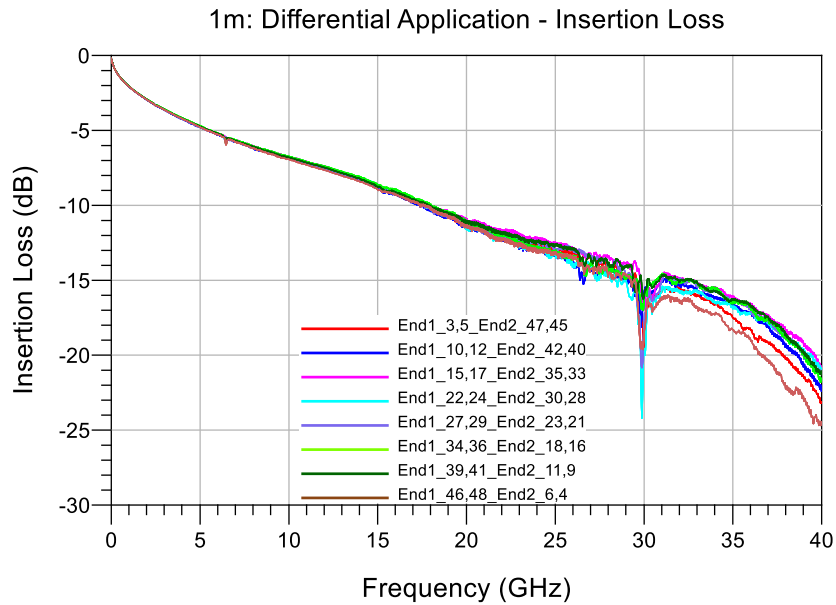

Figure 7

Series: ARC6

Description: 0.635 mm AcceleRate® Slim Body Cable Assembly, 34 AWG, 100 Ω Eye Speed® ultra low skew twinax cable



Differential Application – Return Loss

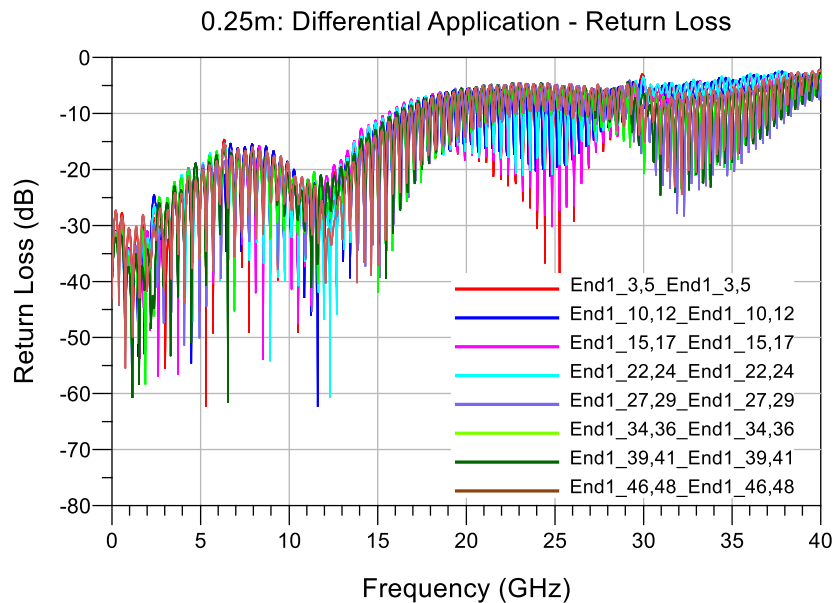

Series: ARC6

Description: 0.635 mm AcceleRate® Slim Body Cable Assembly, 34 AWG, 100 Ω Eye Speed® ultra low skew twinax cable

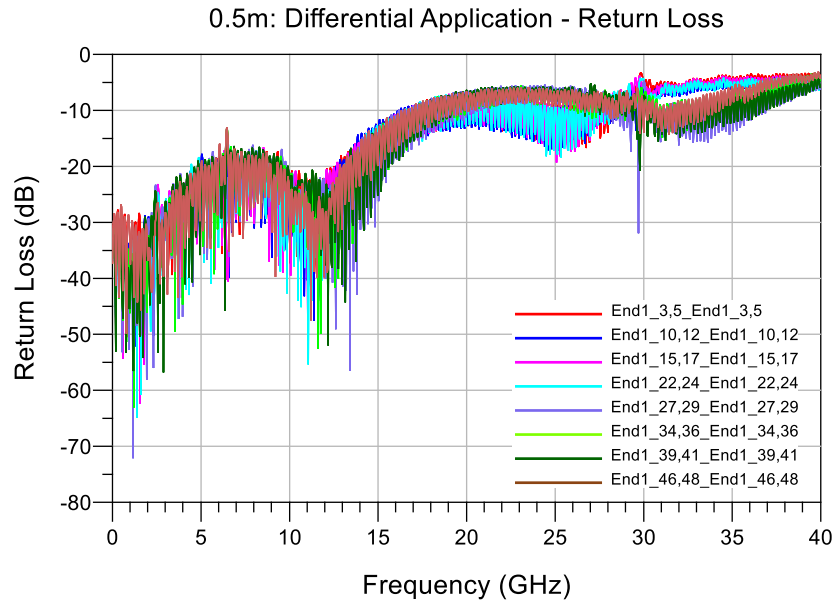

Figure 10

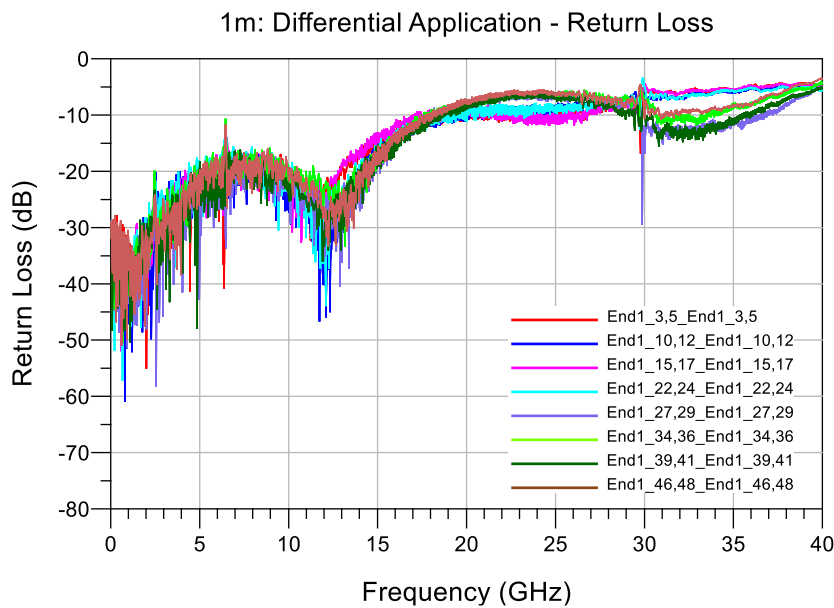

Figure 11

Series: ARC6

Description: 0.635 mm AcceleRate® Slim Body Cable Assembly, 34 AWG, 100 Ω Eye Speed® ultra low skew twinax cable

Differential Application – NEXT Configurations

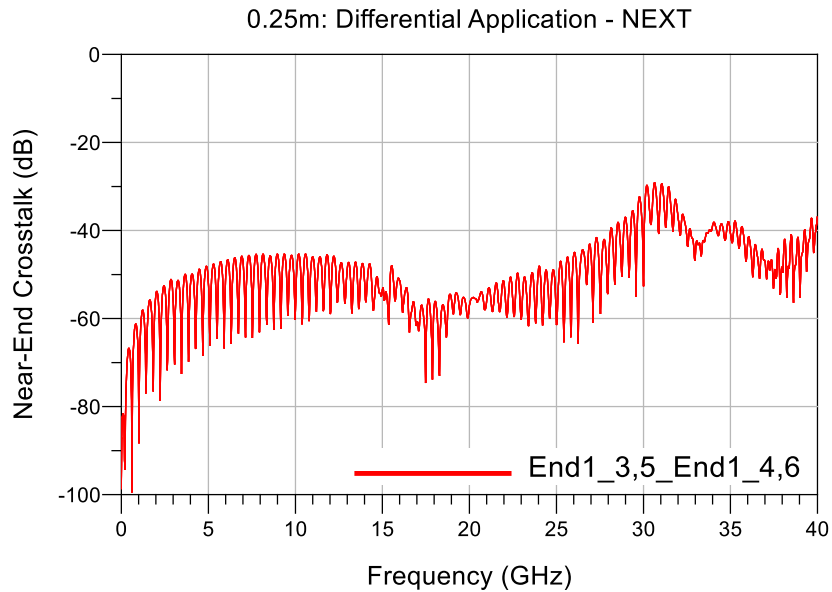

Figure 12

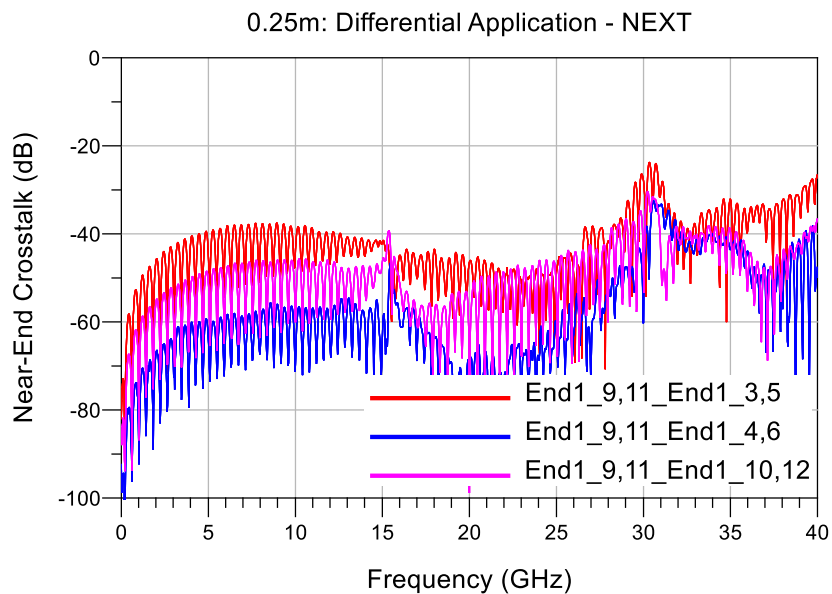

Figure 13

Series: ARC6

Description: 0.635 mm AcceleRate® Slim Body Cable Assembly, 34 AWG, 100 Ω Eye Speed® ultra low skew twinax cable

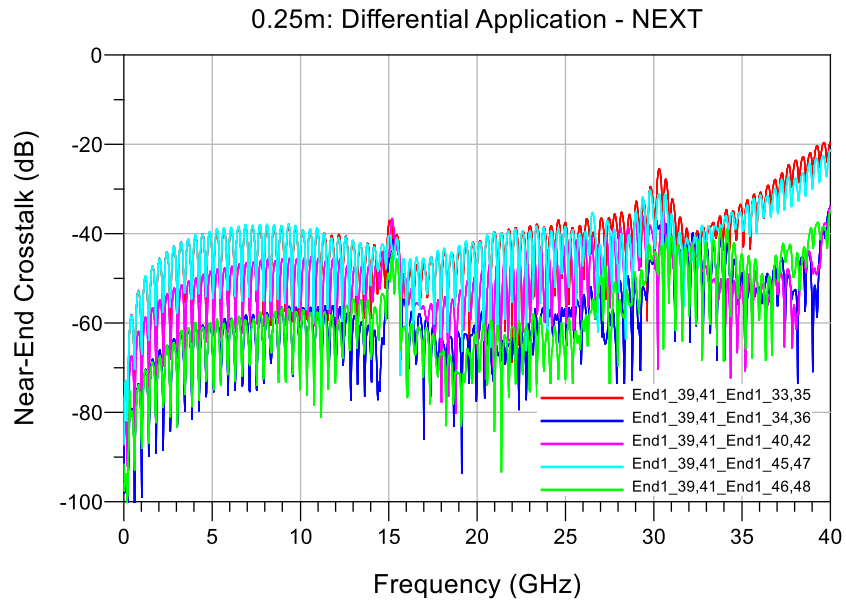

Figure 14

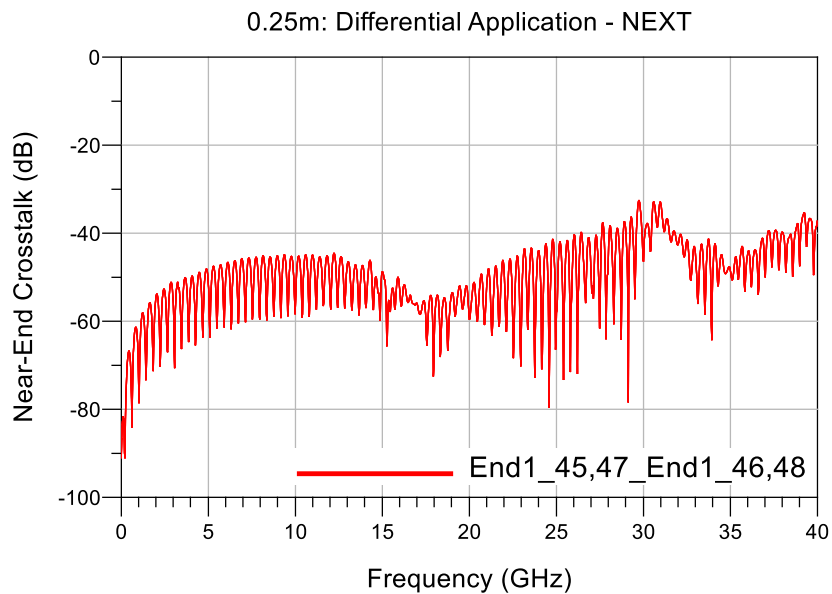

Figure 15

Series: ARC6

Description: 0.635 mm AcceleRate® Slim Body Cable Assembly, 34 AWG, 100 Ω Eye Speed® ultra low skew twinax cable

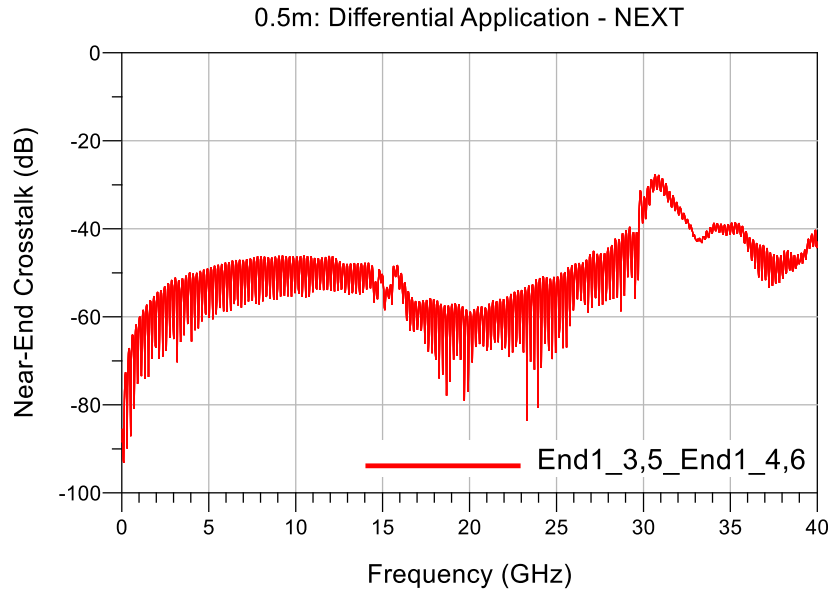

Figure 16

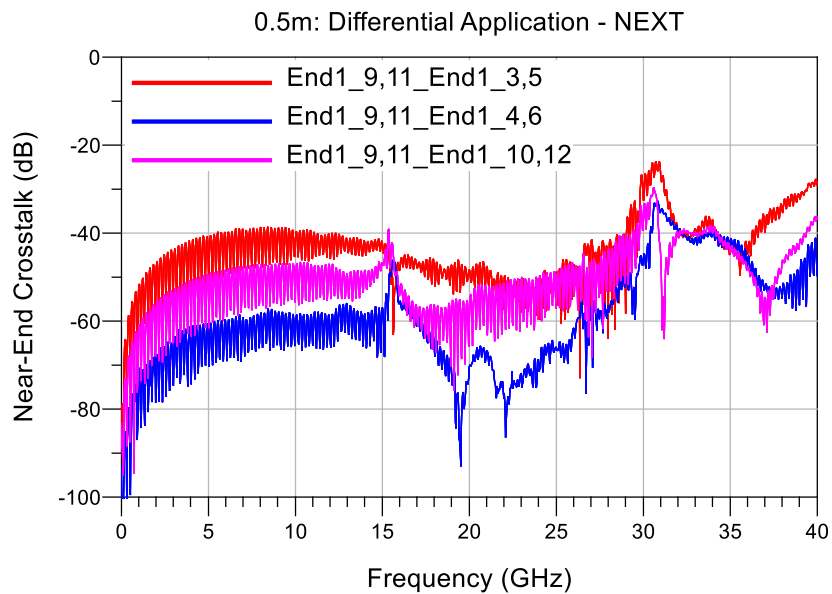

Figure 17

Series: ARC6

Description: 0.635 mm AcceleRate® Slim Body Cable Assembly, 34 AWG, 100 Ω Eye Speed® ultra low skew twinax cable

0.5m: Differential Application - NEXT

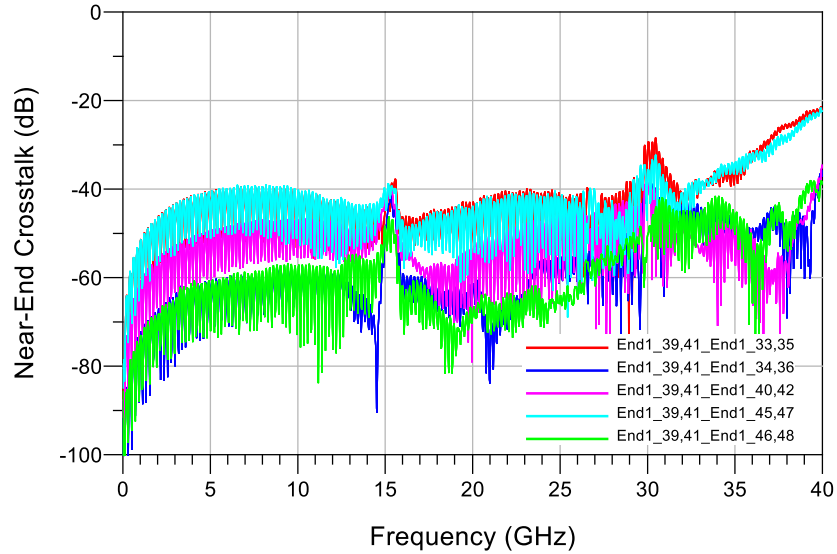

Figure 18

0.5m: Differential Application - NEXT

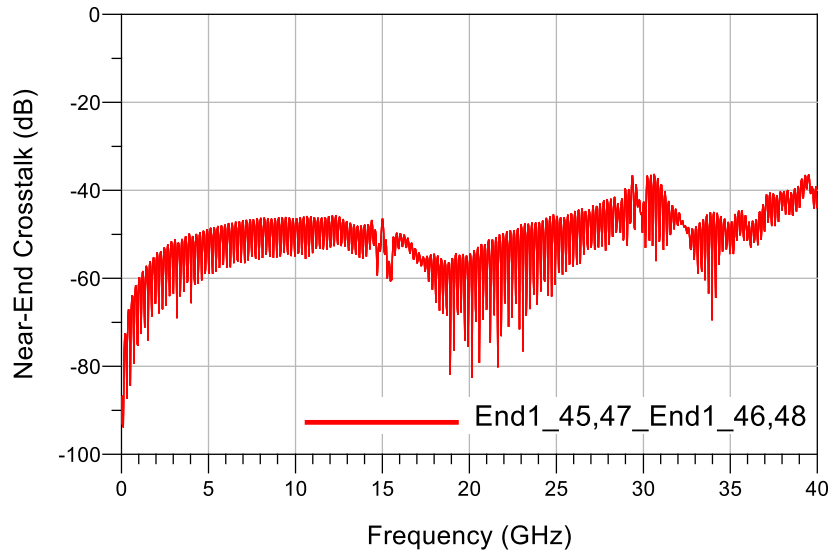

Figure 19

Series: ARC6

Description: 0.635 mm AcceleRate® Slim Body Cable Assembly, 34 AWG, 100 Ω Eye Speed® ultra low skew twinax cable

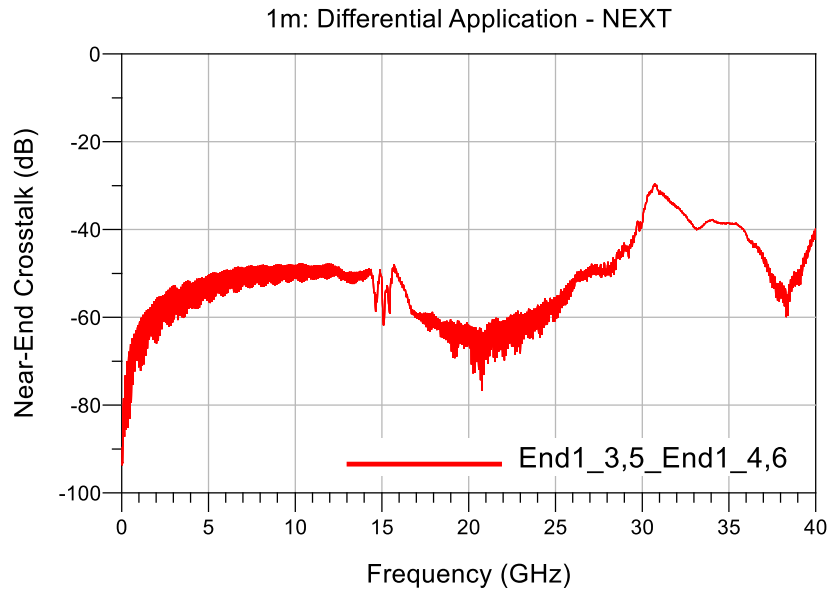

Figure 20

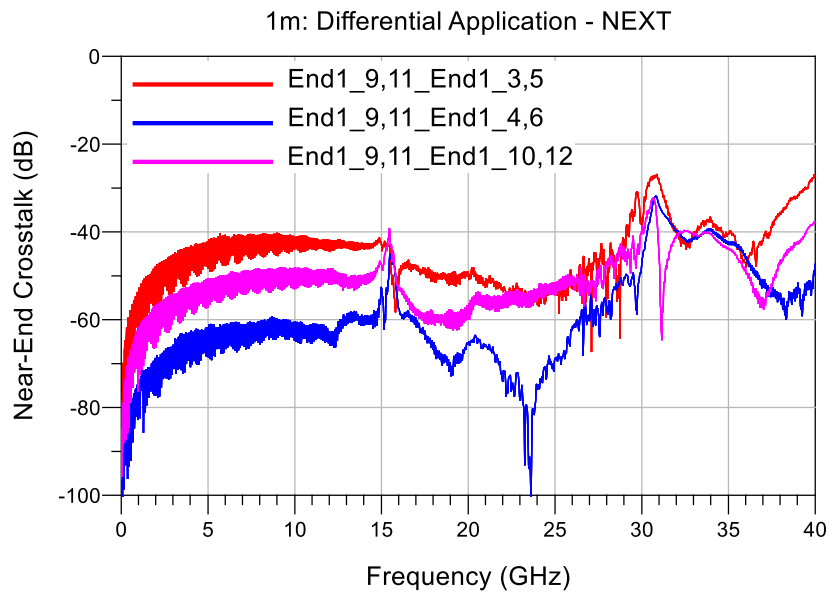

Figure 21

Series: ARC6

Description: 0.635 mm AcceleRate® Slim Body Cable Assembly, 34 AWG, 100 Ω
Eye Speed® ultra low skew twinax cable

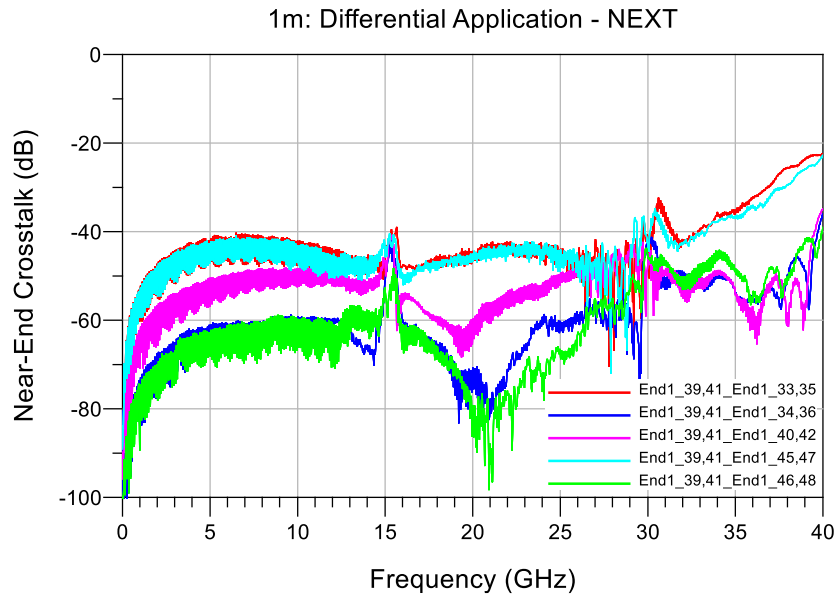

Figure 22

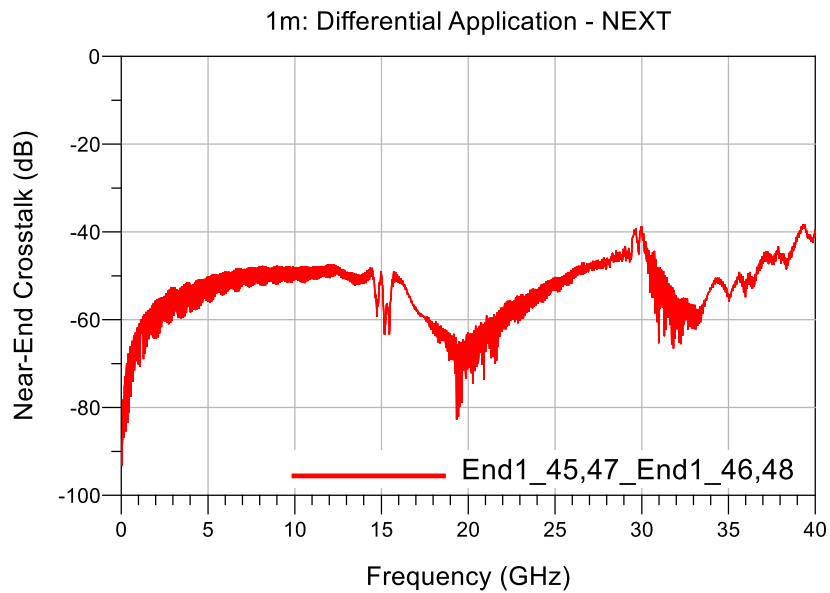

Figure 23

Series: ARC6

Description: 0.635 mm AcceleRate® Slim Body Cable Assembly, 34 AWG, 100 Ω Eye Speed® ultra low skew twinax cable

Differential Application – FEXT Configurations

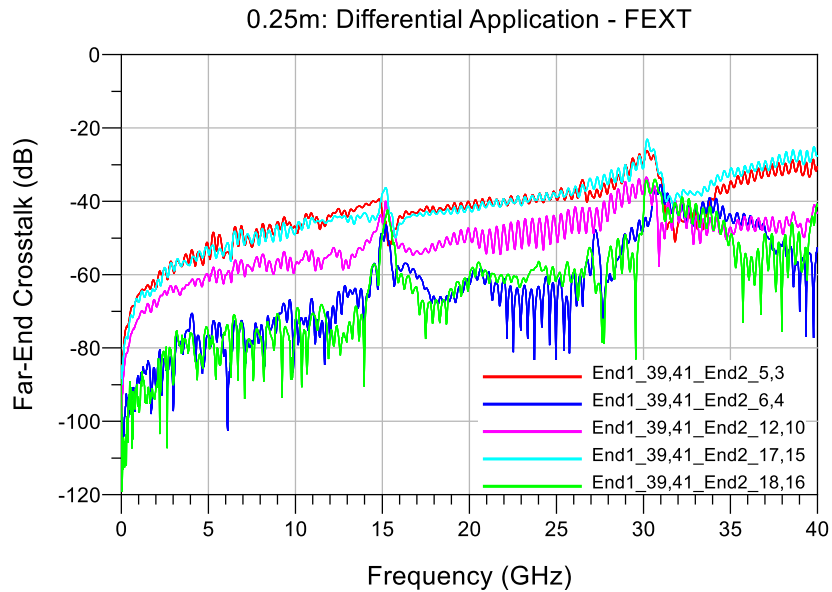

Figure 24

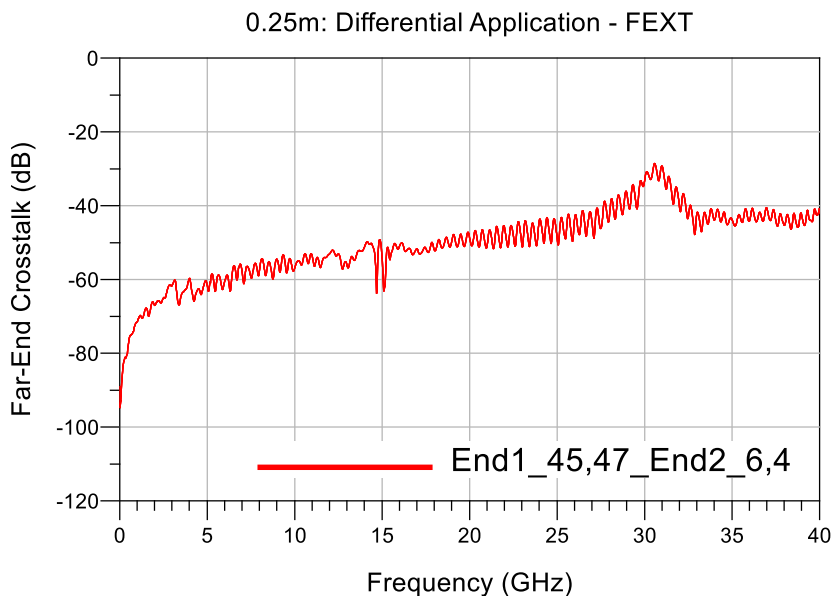

Figure 25

Series: ARC6

Description: 0.635 mm AcceleRate® Slim Body Cable Assembly, 34 AWG, 100 Ω Eye Speed® ultra low skew twinax cable

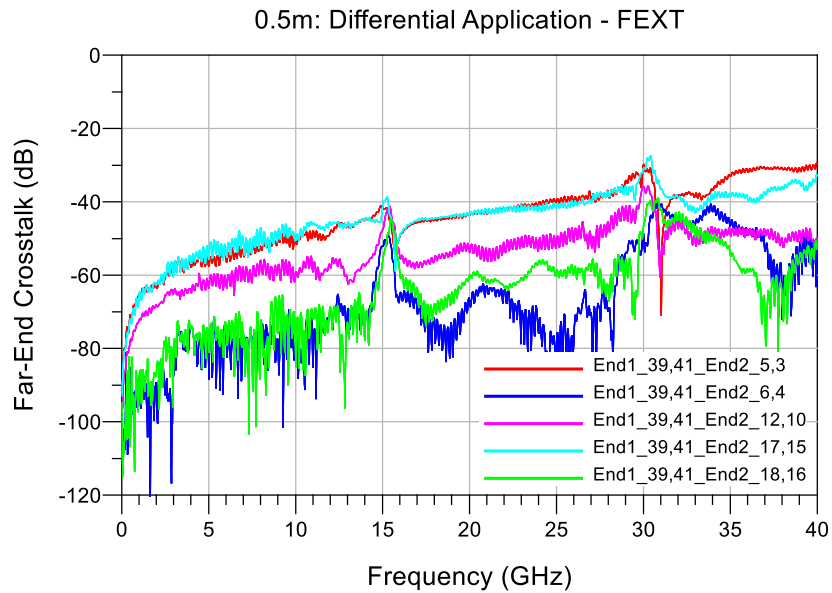

Figure 26

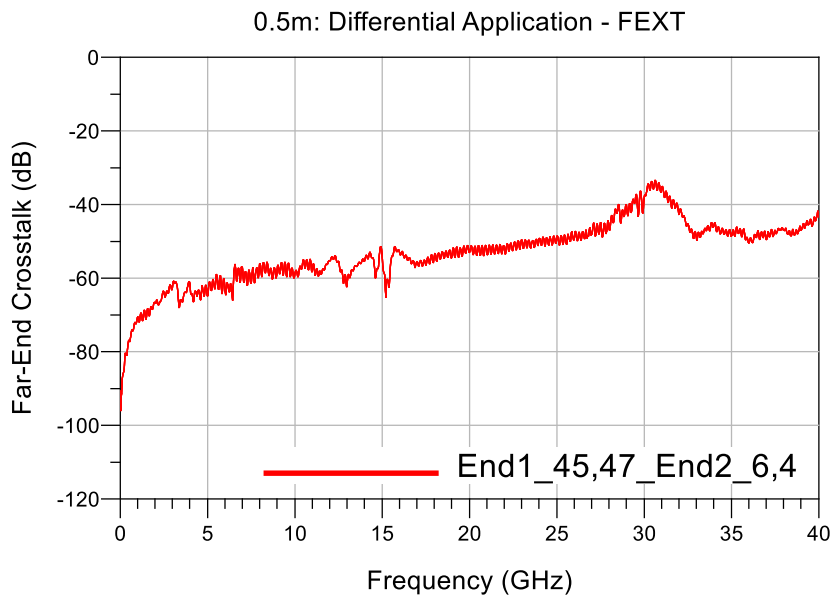

Figure 27

Series: ARC6

Description: 0.635 mm AcceleRate® Slim Body Cable Assembly, 34 AWG, 100 Ω Eye Speed® ultra low skew twinax cable

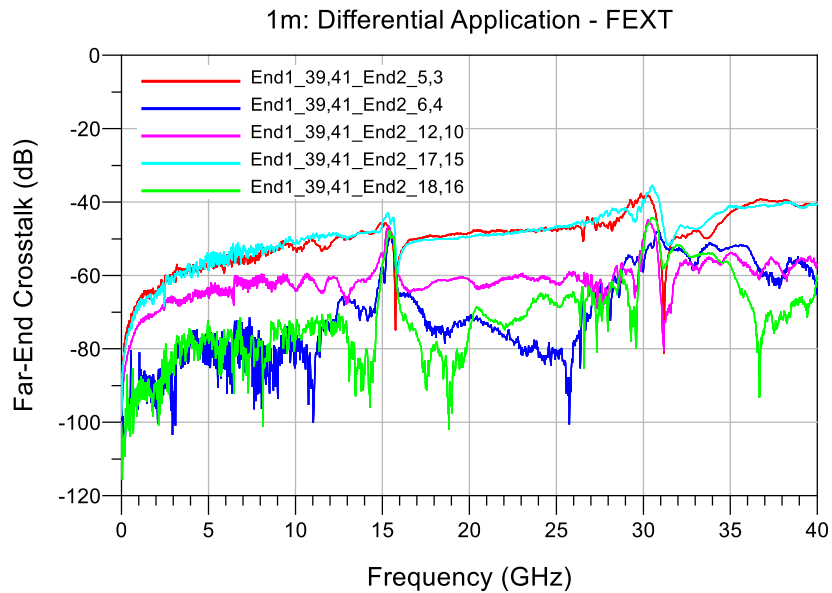

Figure 28

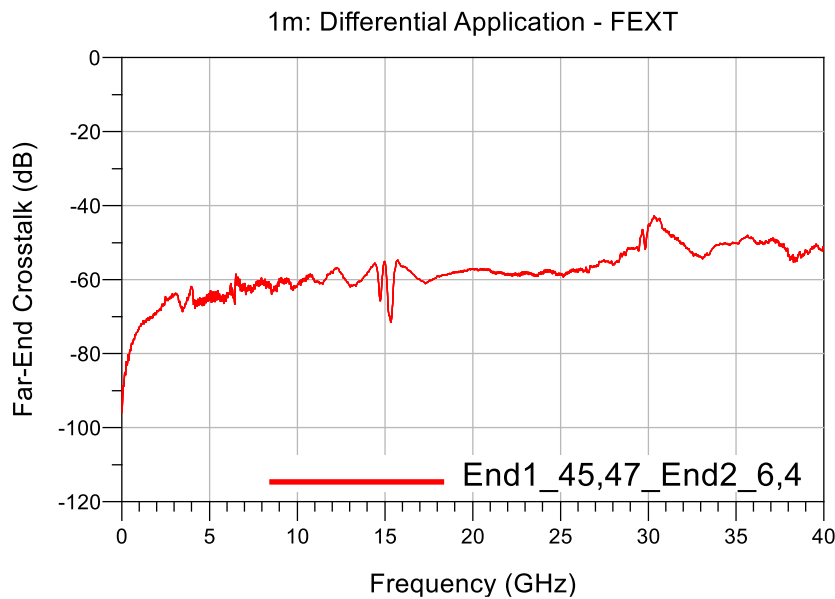

Figure 29

Series: ARC6

Description: 0.635 mm AcceleRate® Slim Body Cable Assembly, 34 AWG, 100 Ω Eye Speed® ultra low skew twinax cable

Differential Application – Differential to Common Mode Conversion

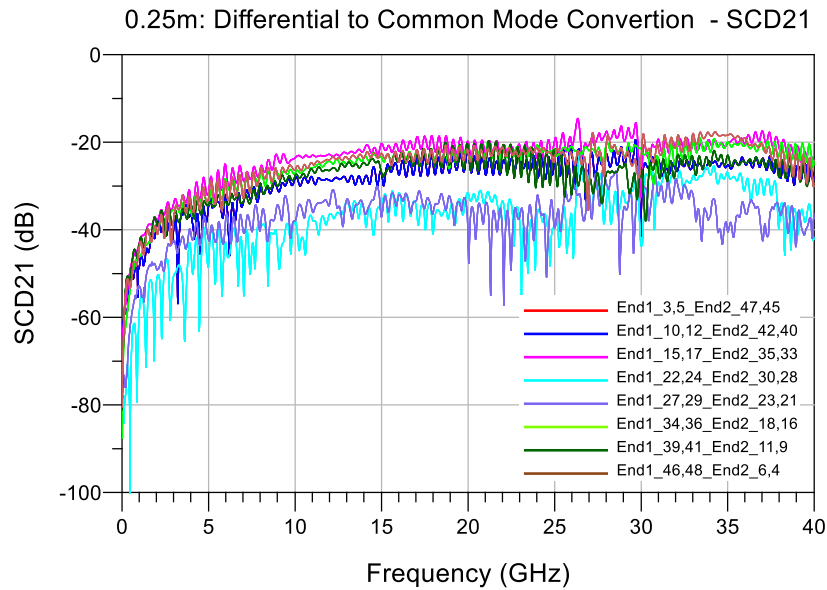

Figure 30

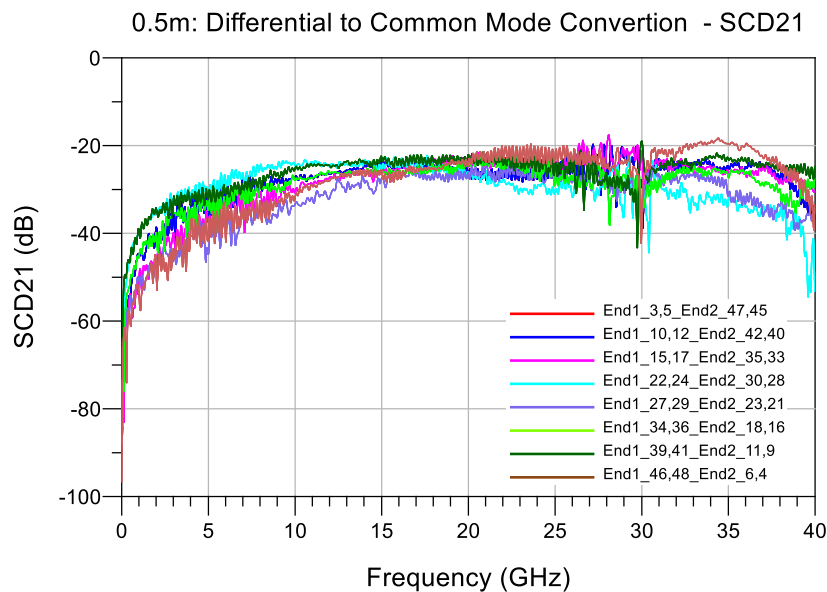

Figure 31

Series: ARC6

Description: 0.635 mm AcceleRate® Slim Body Cable Assembly, 34 AWG, 100 Ω
Eye Speed® ultra low skew twinax cable

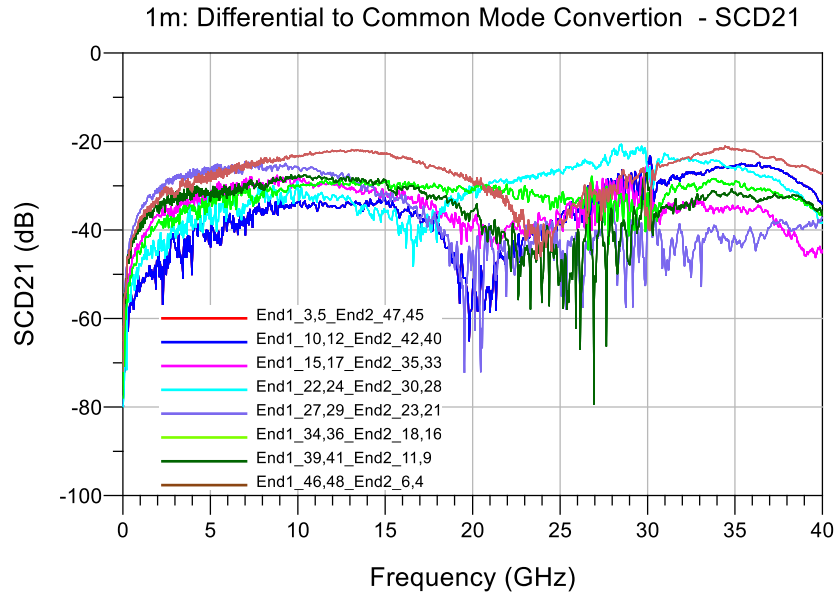

Figure 32

Series: ARC6

Description: 0.635 mm AcceleRate® Slim Body Cable Assembly, 34 AWG, 100 Ω Eye Speed® ultra low skew twinax cable

Appendix B – Time Domain Responses

Differential Application – Input Pulse

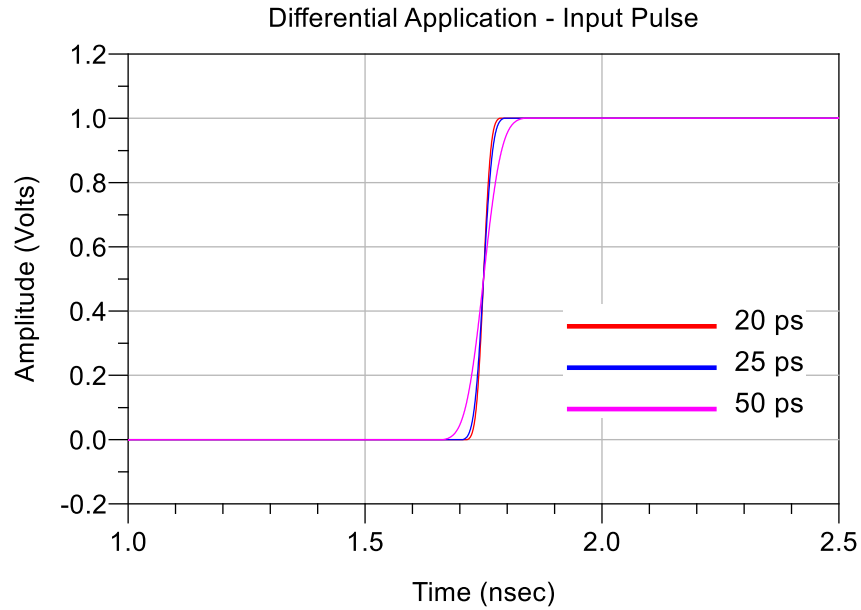

Figure 33

Differential Application – Cable assembly Impedance ARC6-16-10.0-LU-LU-3-1

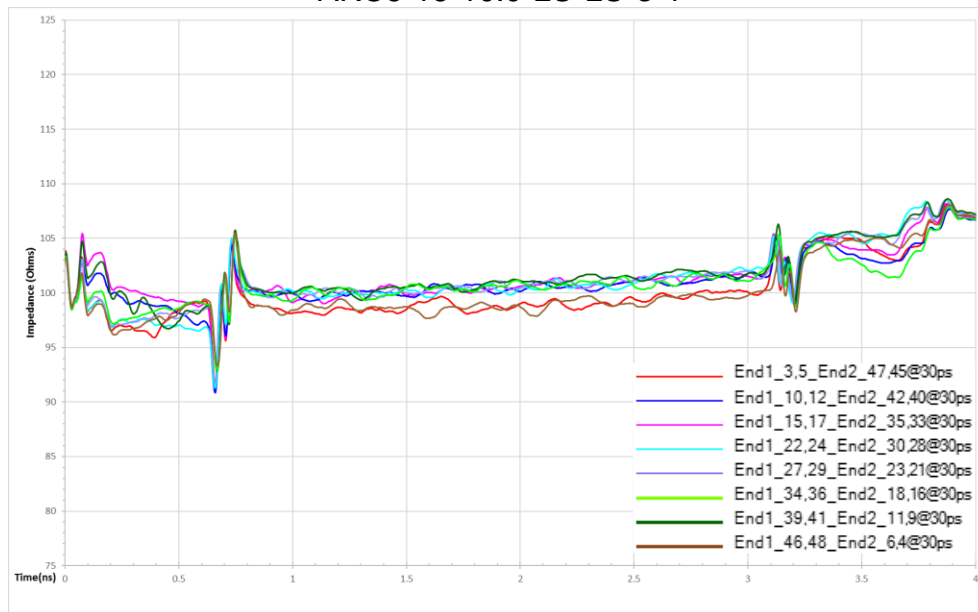

Figure 34

Series: ARC6

Description: 0.635 mm AcceleRate® Slim Body Cable Assembly, 34 AWG, 100 Ω
Eye Speed® ultra low skew twinax cable

Differential Application – Cable assembly Impedance

ARC6-16-10.0-LU-LU-3-1

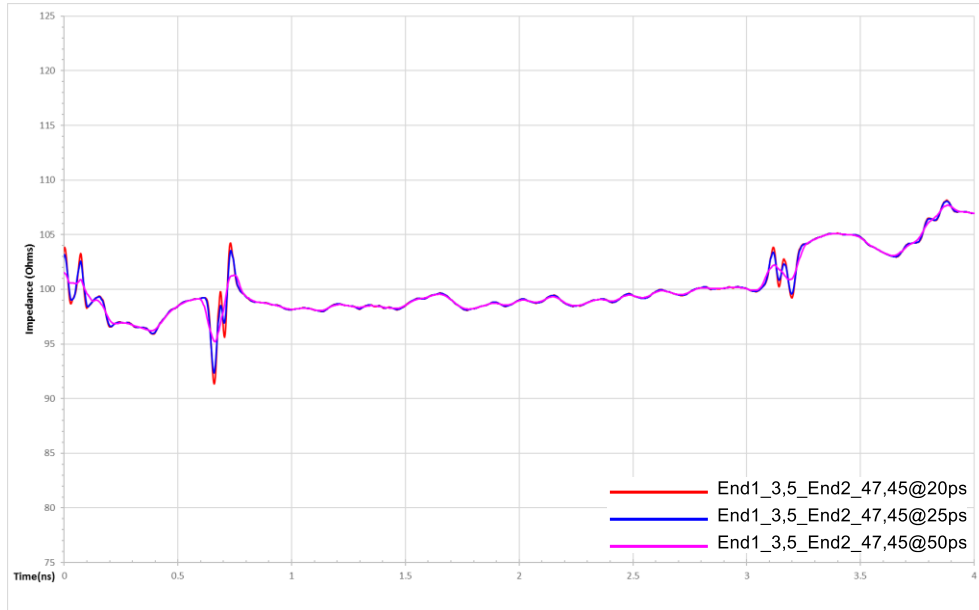

Figure 35

ARC6-16-10.0-LU-LU-3-1

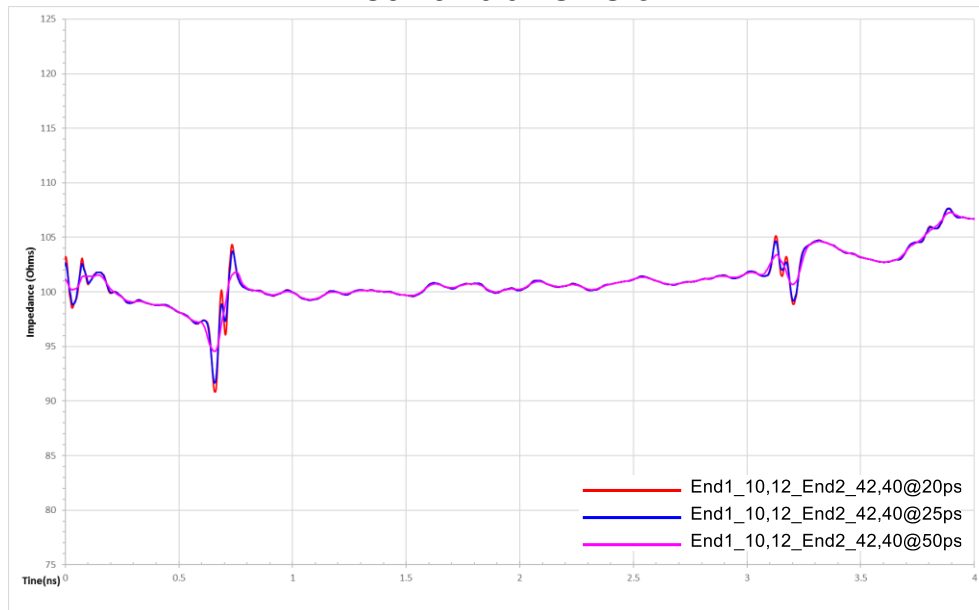

Figure 36

Series: ARC6

Description: 0.635 mm AcceleRate® Slim Body Cable Assembly, 34 AWG, 100 Ω
Eye Speed® ultra low skew twinax cable

ARC6-16-10.0-LU-LU-3-1

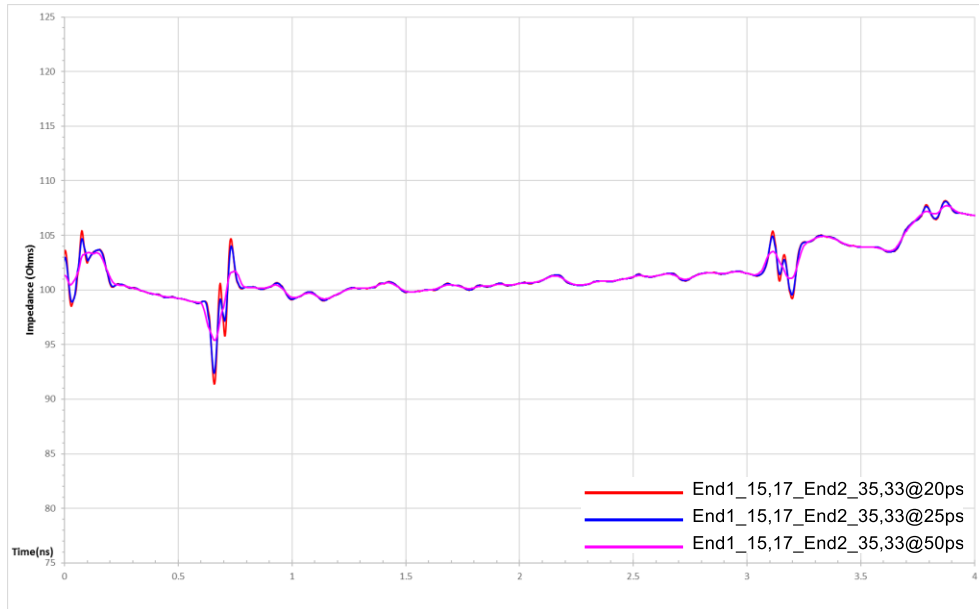

Figure 37

ARC6-16-10.0-LU-LU-3-1

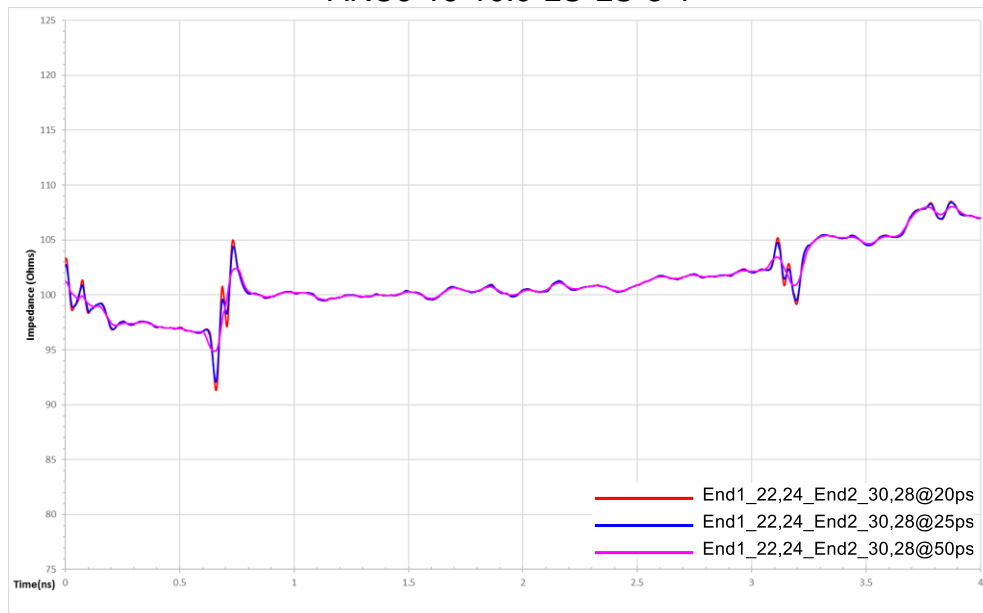

Figure 38

Series: ARC6

Description: 0.635 mm AcceleRate® Slim Body Cable Assembly, 34 AWG, 100 Ω
Eye Speed® ultra low skew twinax cable

ARC6-16-10.0-LU-LU-3-1

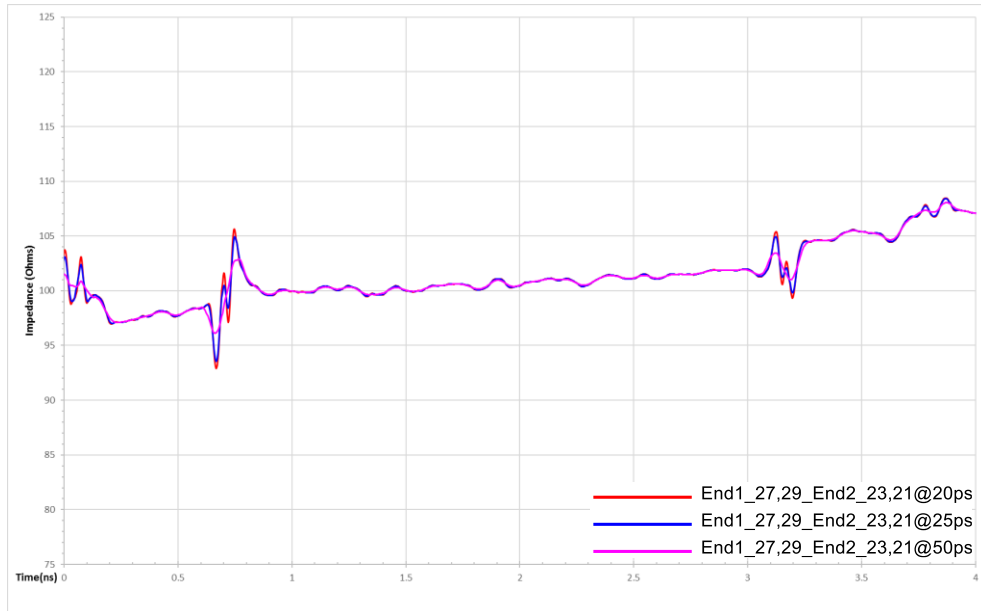

Figure 39

ARC6-16-10.0-LU-LU-3-1

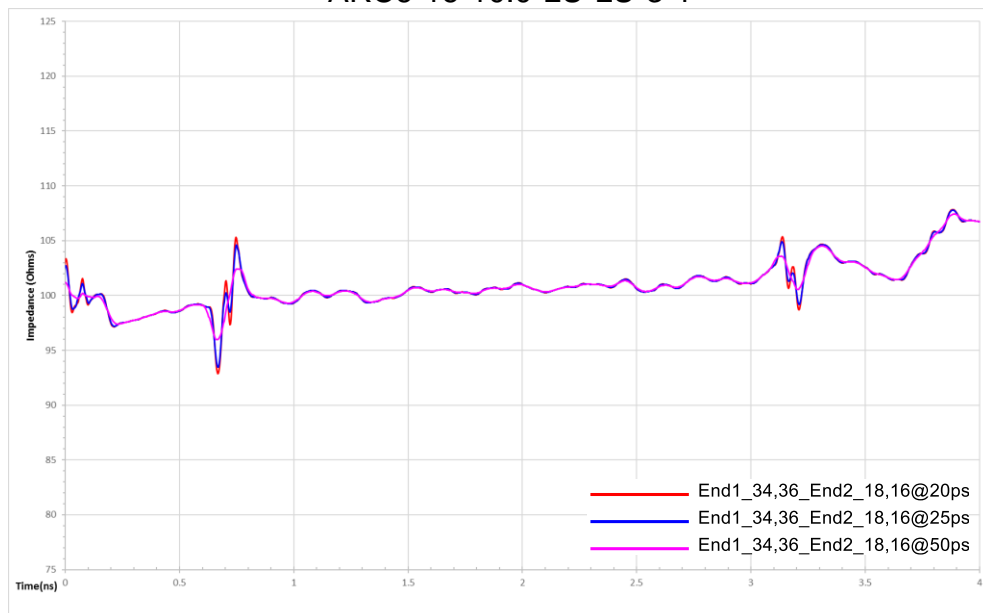

Figure 40

Series: ARC6

Description: 0.635 mm AcceleRate® Slim Body Cable Assembly, 34 AWG, 100 Ω
Eye Speed® ultra low skew twinax cable

ARC6-16-10.0-LU-LU-3-1

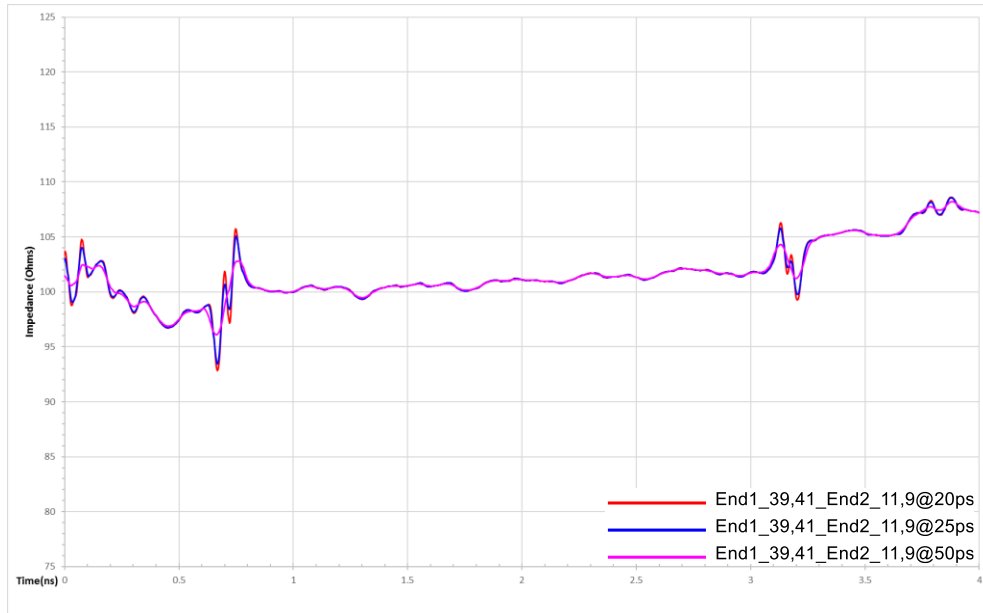

Figure 41

ARC6-16-10.0-LU-LU-3-1

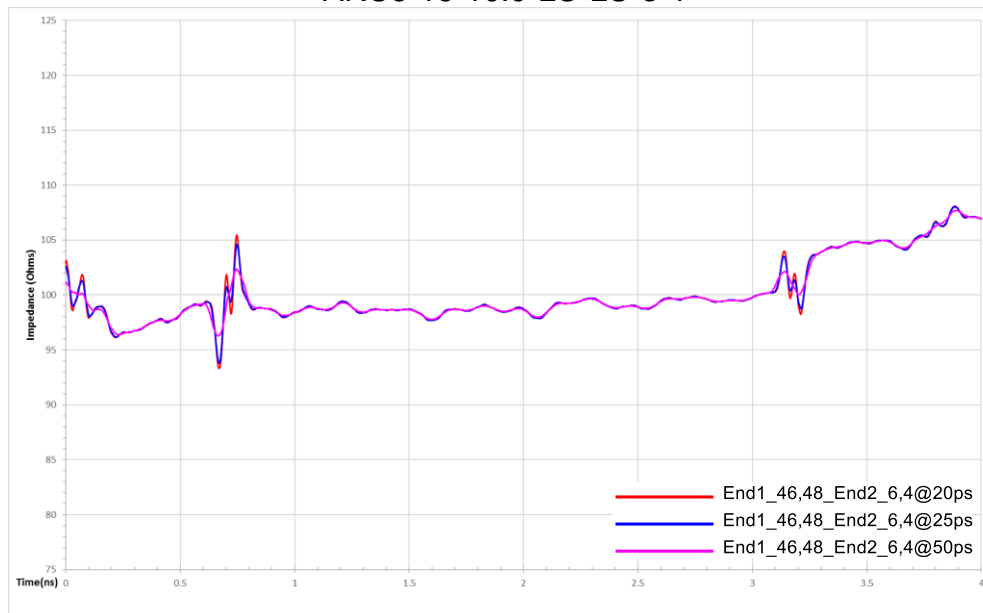

Figure 42

Series: ARC6

Description: 0.635 mm AcceleRate® Slim Body Cable Assembly, 34 AWG, 100 Ω
Eye Speed® ultra low skew twinax cable

Differential Application – Propagation Delay

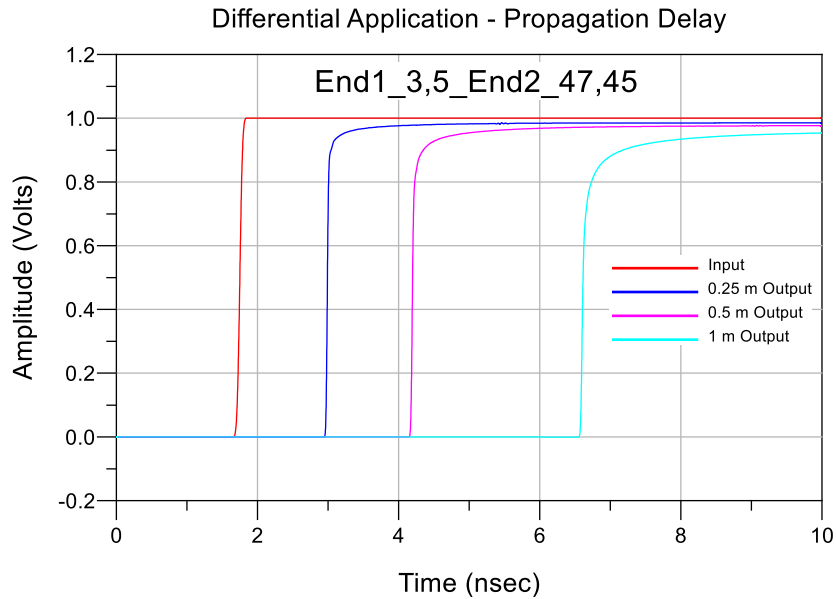

Figure 43

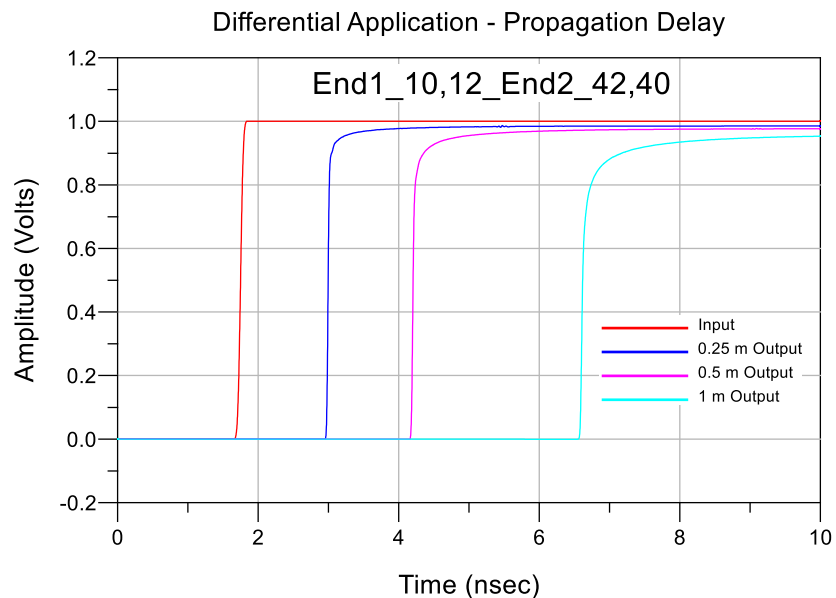

Figure 44

Series: ARC6

Description: 0.635 mm AcceleRate® Slim Body Cable Assembly, 34 AWG, 100 Ω Eye Speed® ultra low skew twinax cable

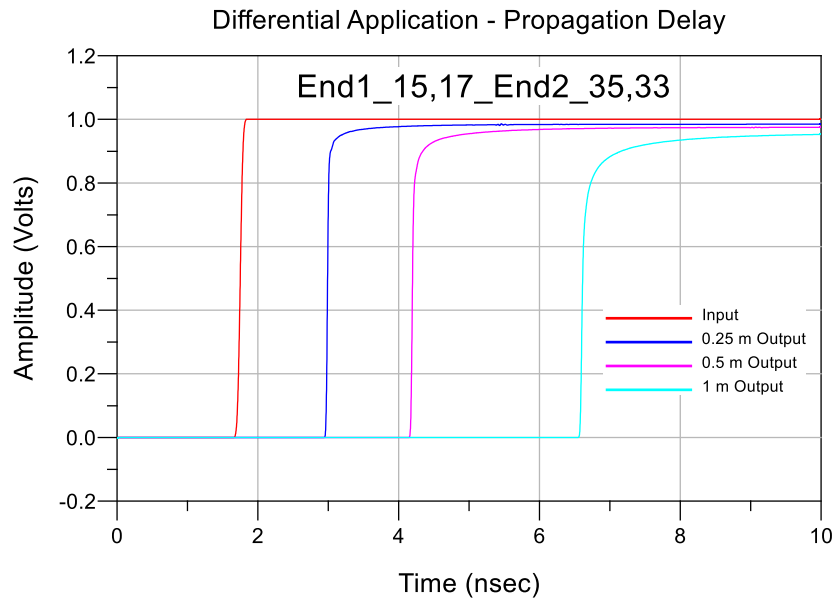

Figure 45

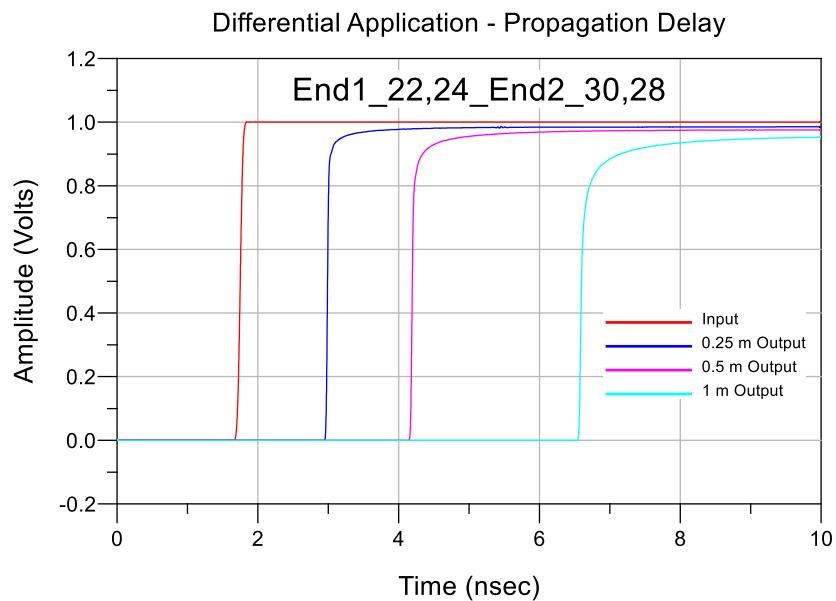

Figure 46

Series: ARC6

Description: 0.635 mm AcceleRate® Slim Body Cable Assembly, 34 AWG, 100 Ω
Eye Speed® ultra low skew twinax cable

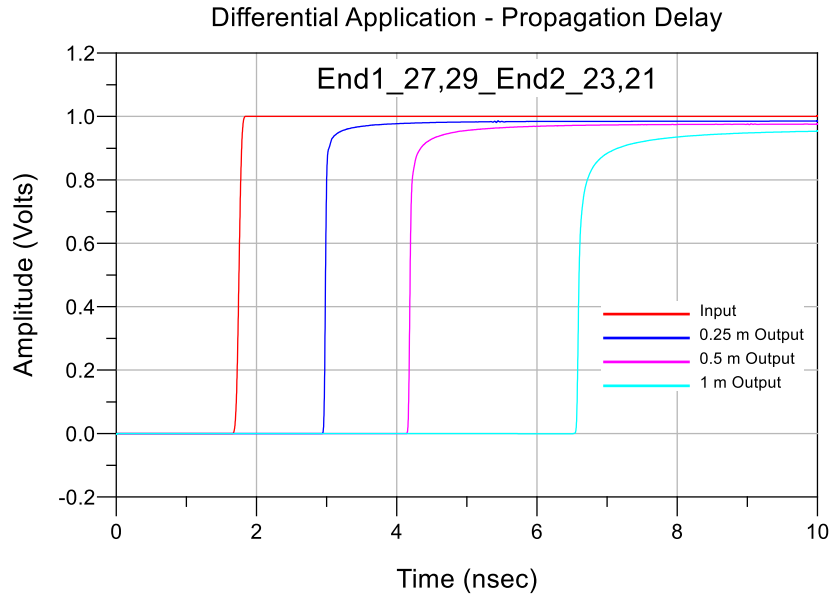

Figure 47

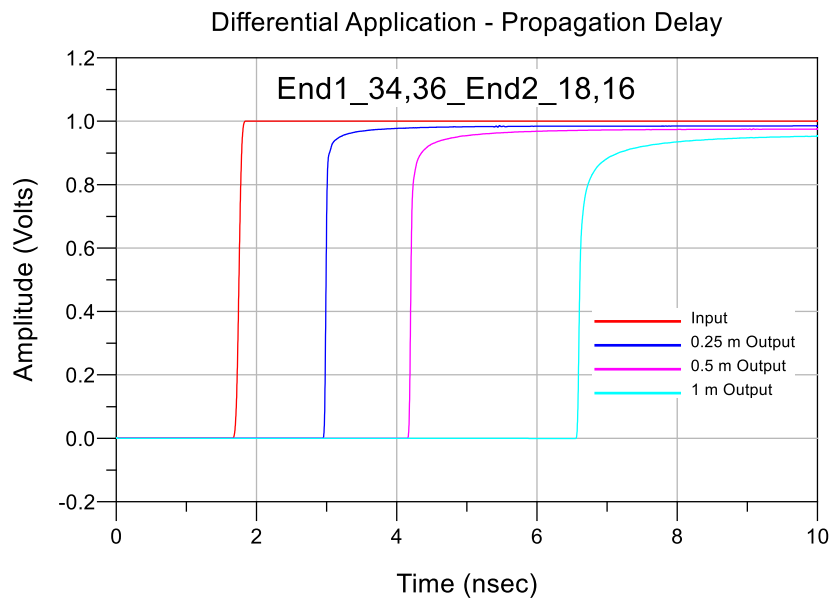

Figure 48

Series: ARC6

Description: 0.635 mm AcceleRate® Slim Body Cable Assembly, 34 AWG, 100 Ω
Eye Speed® ultra low skew twinax cable

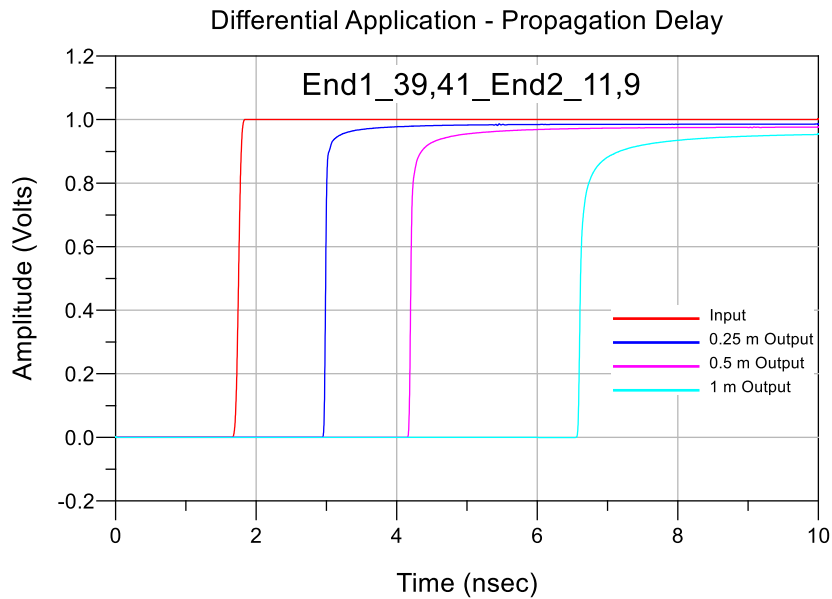

Figure 49

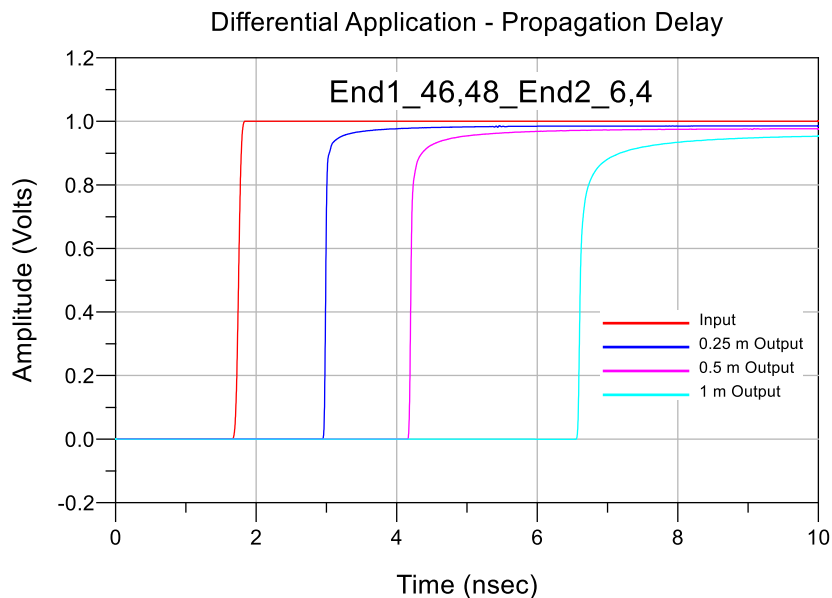

Figure 50

Series: ARC6

Description: 0.635 mm AcceleRate® Slim Body Cable Assembly, 34 AWG, 100 Ω Eye Speed® ultra low skew twinax cable

Appendix C – Product and Test System Descriptions

Product Description

Product test samples are 0.635 mm (.025") ARC6 Slim Body Cable Assemblies. The part numbers are ARC6-16-10.0-LU-LU-3-1, ARC6-16-20.0-LU-LU-3-1 and ARC6-16-40.0-LU-LU-3-1. They mate with ARF6-16-X-D-A-X-TR. A photo of the mated test article mounted to SI test boards is shown below.

The cable assembly terminations had a particular signal line configuration. There are a total of 16 pairs per row, the signal line numbers are shown in Table 3.

J1	1	3	5	7	9	11	13	15	17	19	21	23	25	27	29	31	33	35	37	39	41	43	45	47	49	2	4	6	8	10	12	14	16	18	20	22	24	26	28	30	32	34	36	38	40	42	44	46	48	50			
NAME	G	PAIR	G	PAIR	G	PAIR	G	PAIR	G	PAIR	G	PAIR	G	PAIR	G	PAIR	G	PAIR	G	PAIR	G	PAIR	G	PAIR	G		G	PAIR	G	PAIR	G	PAIR	G	PAIR	G	PAIR	G	PAIR	G	PAIR	G	PAIR	G	PAIR	G	PAIR	G	PAIR	G	PAIR	G	PAIR	G
J2	49	47	45	43	41	39	37	35	33	31	29	27	25	23	21	19	17	15	13	11	9	7	5	3	1	50	48	46	44	42	40	38	36	34	32	30	28	26	24	22	20	18	16	14	12	10	8	6	4	2			

Table 3: Signal line numbers

Test System Description

The test fixtures are composed of six-layer Itera MT40 material with 100Ω differential signal trace and pad configurations designed for the electrical characterization of Samtec high speed cable assembly products. A PCB mount 2.4mm connector is used to interface the PNA test cables to the test fixtures. Optimization of the 2.4mm launch was performed using full wave simulation tools to minimize reflections. The test fixtures and calibration kit are specific to the ARx6 series connector set and identified by part number PCB-109926-SIG.

PCB-109926-SIG Test Fixtures

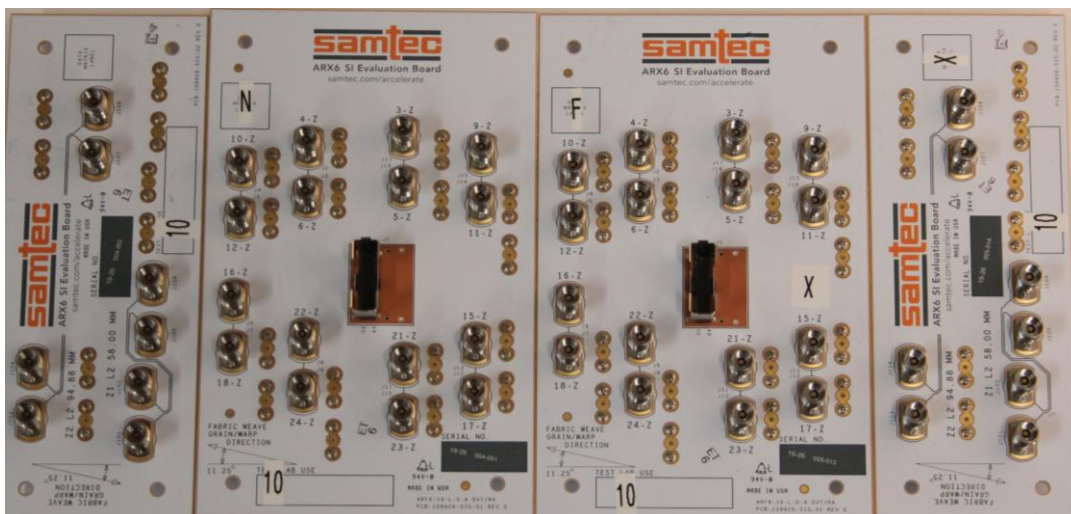

Figure 51

Series: ARC6

Description: 0.635 mm AcceleRate® Slim Body Cable Assembly, 34 AWG, 100 Ω Eye Speed® ultra low skew twinax cable

Artwork of the PCB design is shown below.

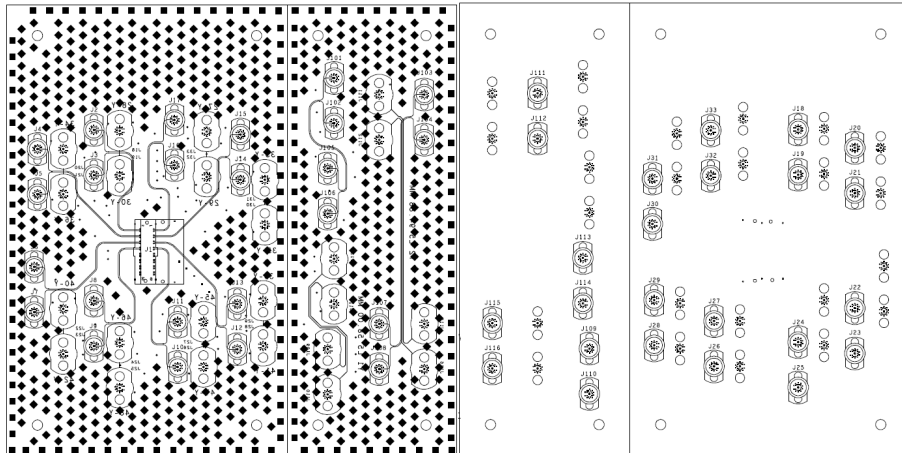

Figure 52

PCB Fixtures

The test fixtures used are as follows:

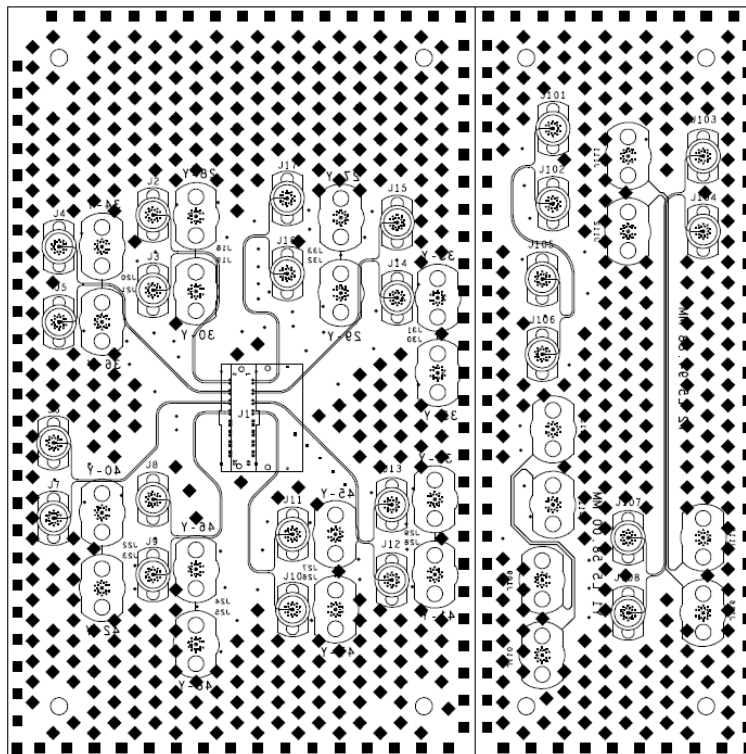

Figure 53

Series: ARC6

Description: 0.635 mm AcceleRate® Slim Body Cable Assembly, 34 AWG, 100 Ω
Eye Speed® ultra low skew twinax cable

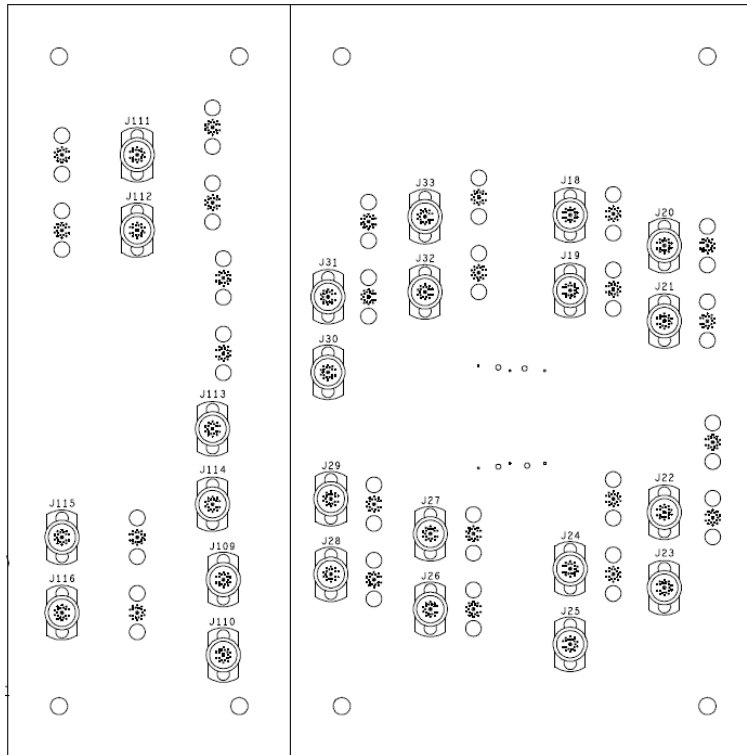

Figure 54

PCB-109926-SIG – ARC6 Cable Test Board

Series: ARC6

Description: 0.635 mm AcceleRate® Slim Body Cable Assembly, 34 AWG, 100 Ω
Eye Speed® ultra low skew twinax cable

Appendix D – Test and Measurement Setup

For frequency domain measurements, the test instrument is the Agilent N5227B PNA-L network analyzer. Frequency domain data and graphs are extracted from the instrument by AFR application. The network analyzer is configured as follows:

Start Frequency – 10 MHz

Stop Frequency – 67 GHz

IFBW – 1 KHz

N5227B Measurement Setup

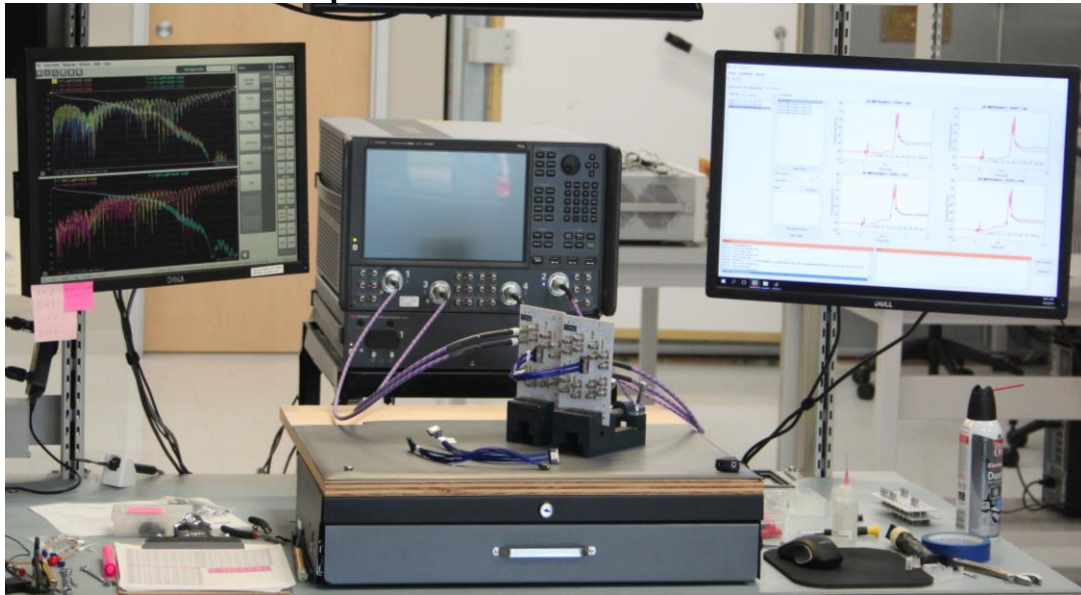

Figure 55

Test Instruments

<u>QTY</u>	<u>Description</u>
1	Agilent N5227B PNA-L Network Analyzer (10 MHz to 67 GHz)
1	Agilent N4694-60003 ECAL Module (10 MHz to 67 GHz)

Test Cables & Adapters

<u>QTY</u>	<u>Description</u>
4	Gore 0F0CACB036.0-LF (DC to 67 GHz)

Series: ARC6

Description: 0.635 mm AcceleRate® Slim Body Cable Assembly, 34 AWG, 100 Ω
Eye Speed® ultra low skew twinax cable

For impedance measurements, the test instrument is the Keysight DCA-X86100D Wide-Bandwidth Oscilloscope Mainframe. The impedance data and profiles are obtained directly from the instrument. The Digital Analyzer is configured as follows:

Vertical Scale: 5 ohm / Div

Horizontal Resolution: 2.5ps

Averages: 128

DCA-X86100D Measurement Setup

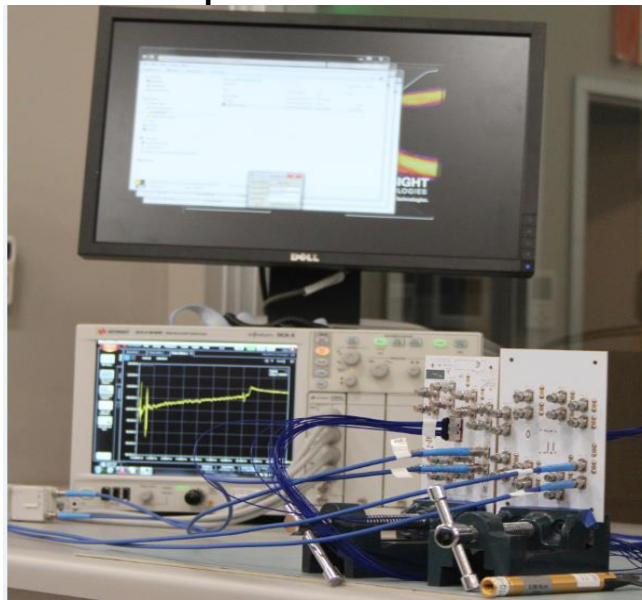

Figure 56

Test Instruments

<u>QTY</u>	<u>Description</u>
1	Keysight DCA-X86100D Wide-Bandwidth Oscilloscope Mainframe

Test Cables & Adapters

<u>QTY</u>	<u>Description</u>
4	Junkosha J12J103834-00

Series: ARC6

Description: 0.635 mm AcceleRate® Slim Body Cable Assembly, 34 AWG, 100 Ω
Eye Speed® ultra low skew twinax cable

Appendix E - Frequency and Time Domain Measurements

Frequency (S-Parameter) Domain Procedures

The quality of any data taken with a network analyzer is directly related to the quality of the calibration standards and the use of proper test procedures. For this reason, extreme care is taken in the design of the calibration standards, the SI test boards, and the selection of the PCB vendor.

A coaxial SOLT calibration is performed using a N4694-60003 ECAL module. Then DUT measurements are performed under SOLT calibration. The measurements include the effect of test fixture. The measurements of the 2X THRU line standards are required to remove the test fixture effect.

Time Domain Procedures

Mathematically, Frequency Domain data can be transformed to obtain a Time Domain response. Perfect transformation requires Frequency Domain data from DC to infinity Hz. Fortunately, a very accurate Time Domain response can be obtained with bandwidth-limited data, such as measured with modern network analyzer.

The Time Domain responses were generated using Keysight ADS 2017 update 1. This tool has a transient convolution simulator, which can generate a Time Domain response directly from measured S-Parameters. An example of a similar methodology is provided in the Samtec Technical Note on domain transformation.

http://suddendocs.samtec.com/notesandwhitepapers/tech-note_using-plts-for-time-domain-data_web.pdf

Propagation Delay (TDT)

The Propagation Delay is a measure of the Time Domain delay through the cable assembly and footprint. A step pulse is applied to the touchstone model of the cable assembly and the transmitted voltage is monitored. The same pulse is also applied to a reference channel with zero loss, and the Time Domain pulses are plotted on the same figure.

The difference in time, measured at the 50% point of the step voltage is the propagation delay.

Series: ARC6

Description: 0.635 mm AcceleRate® Slim Body Cable Assembly, 34 AWG, 100 Ω
Eye Speed® ultra low skew twinax cable

Impedance (TDR)

Measurements involving digital pulses are performed using either Time Domain Reflectometer (TDR) or Time Domain Transmission (TDT) methods. The TDR method is used for the impedance measurements in this report.

The signal line(s) of the SUT's is energized with a TDR pulse and the far-end of the energized signal line is terminated in the test systems characteristic impedance (e.g.; 50 Ω or 100 Ω terminations). By terminating the adjacent signal lines in the test systems characteristic impedance, the effects on the resultant impedance shape of the waveform is limited.

Series: ARC6

Description: 0.635 mm AcceleRate® Slim Body Cable Assembly, 34 AWG, 100 Ω
Eye Speed® ultra low skew twinax cable

Appendix F – Glossary of Terms

ADS – Keysight Advanced Design System

AFR – Automatic Fixture Removal

PCB – Printed Circuit Board

SUT – System Under Test

SOLT – acronym used to define Short, Open, Load & Thru Calibration Standards

TDR – Time Domain Reflectometry

TDT – Time Domain Transmission